

Cremagliere standard

Standard racks

Cremagliere a settori in tecnopolimero, angolo di pressione 20° secondo DIN 782.

MATERIALE

Tecnopolimero a base poliammidica, rinforzato con fibra di vetro, colore: grigio/nero.

ESECUZIONE

Stampaggio ad iniezione.

Section racks in technopolymer, pressure angle 20° according to DIN 782.

MATERIAL

Polyamide-based technopolymer, reinforced with glass fiber, color: grey/black.

PRODUCTION

Injection molding.

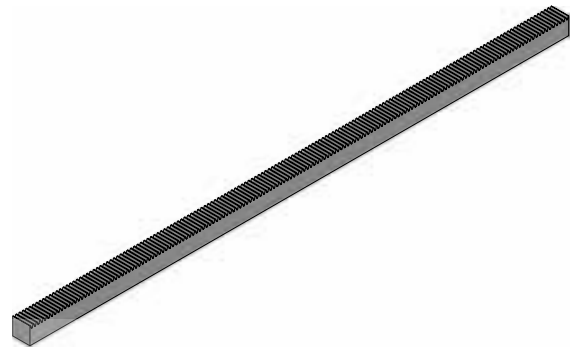

COD.	MODULO/MODULE	A	B	L	Fmax sul dente/ Fmax on tooth (N)	STOCK
CE05X250	0,5	8	8	250	99,3	•
CE1X150	1	15	15	150	372,4	•
CE1X250	1	15	15	250	372,4	•
* CE2X1000-L	2	20	20	1000	-	•
* CE3X1000-L	3	30	30	1000	-	•

* Ottenute da lavorazione / Machinery process

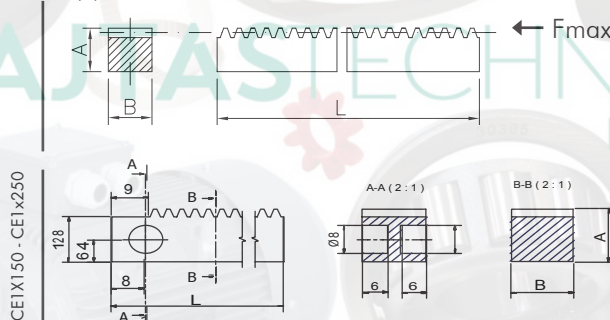

COD.	MODULO/MODULE	VERSIONE/ VERSION	A	B	C	L	Fmax sul dente/ Fmax on tooth (N)	STOCK
CE1X150N	1	N	15	15,5	25,5	150	372,4	•
CE1X250N	1	N	15	15,5	25,5	250	372,4	•
CE1X150S	1	S	15	15,5	26,5	150	372,4	•
CE1X250S	1	S	15	15,5	26,5	250	372,4	•
CE1X150T	1	T	15	13	4	150	372,4	•
CE1X250T	1	T	15	13	4	250	372,4	•

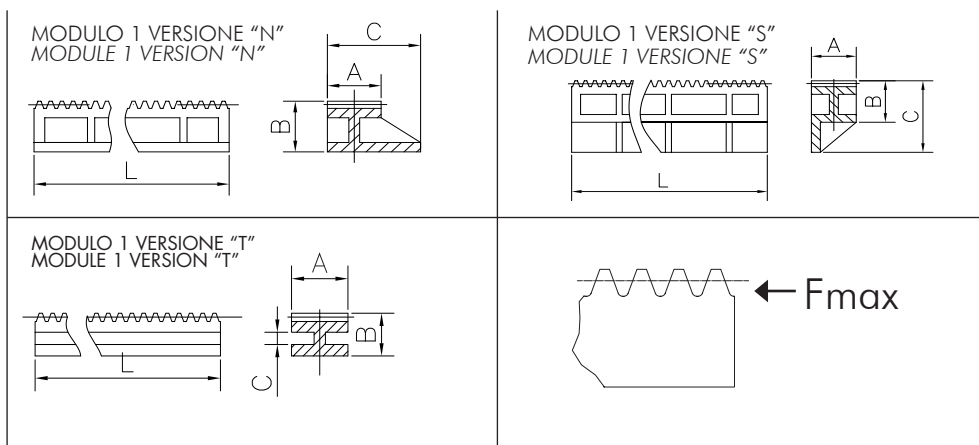

Le U.M. non specificate sono da intendersi in [mm]
The U.M. if not specified are in [mm]

*Proprietà dei modelli riservata ai termini di legge. Disegni e immagini non riproducibili se non citando la fonte.
Property of models reserved for statutory terms. Drawings and images can not be reproduced unless quoting the source.



Cremagliere standard con anima in acciaio

Standard racks with steel core

Cremagliere a settori in tecnopolimero con anima in acciaio, angolo di pressione 20° secondo DIN 782

MATERIALE

Tecnopolimero a base poliammidica, rinforzato con fibra di vetro, colore: grigio.
Acciaio: Fe360

ESECUZIONE

Costampaggio ad iniezione.

Section racks in technopolymer with steel core, pressure angle 20° according to DIN 782

MATERIAL

Polyamide-based technopolymer, reinforced with glass fiber, color: grey.
Steel: Fe360

PRODUCTION

Co-injection molding.

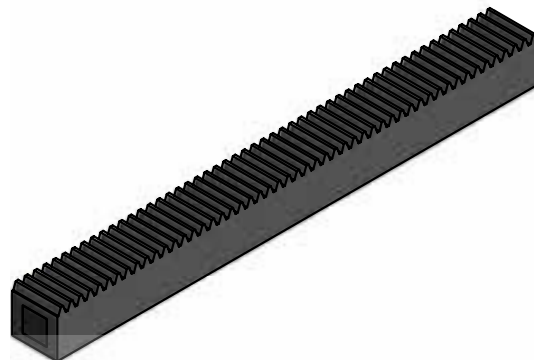

COD.	MODULO/ MODULE	A	B	ANIMA IN ACCIAIO/ STEEL CORE	L	F _{max} sul dente/ F _{max} on tooth (N)	STOCK	Cremagliere di precisione/ precision racks
CE1X350	1	15	15	8 x 8	350	372,4	•	•
CE15X250	1,5	17	17	8 x 8	250	633,1	•	•
CE15X500	1,5	17	17	8 x 8	565,2	633,1	•	•
CE15X1000	1,5	17	17	8 x 8	1000	633,1	•	•
CE2X250	2	20	20	10 x 10	250	993,1	•	•
CE2X500	2	20	20	10 x 10	565,2	993,1	•	•
CE2X1000	2	20	20	10 x 10	1000	993,1	•	•
CE3X250	3	30	30	15 x 15	250	2234,5	•	•
CE3X500	3	30	30	15 x 15	500	2234,5	•	•
CE3X1000	3	30	30	15 x 15	1000	2234,5	•	•
CE4X1000	4	28	20	10 x 10	1000	1986,2	•	•

