



KEYLESS LOCKING DEVICES





SIT-LOCK®
INTRODUCTION

Pag.

3 ÷ 13



SIT-LOCK®
INTERNAL LOCKING DEVICE
SELF-CENTERING

15 ÷ 41



SIT-LOCK®
INTERNAL LOCKING DEVICE
NOT SELF-CENTERING

43 ÷ 55



SIT-LOCK®
SHRINK DISC

57 ÷ 74



SIT-LOCK®
LOCKING DEVICES
FOR APPLICATIONS WITH
HIGH BENDING MOMENTS

75 ÷ 80



SIT-LOCK KEYLESS LOCKING DEVICES

SIT-LOCK® Keyless locking devices

INDICE

SIT-LOCK®	
Keyless locking devices for shaft-hub connection	PAG.
SIT-LOCK® keyless locking device advantages compared to conventional systems	3 - 4
Formulas for correct SIT-LOCK® locking device use	5
Calculating the minimum hub diameter D_{min}	6 - 7
SIT-LOCK® locking device features	8 ÷ 11
SIT-LOCK® applications	12 - 13
INTERNAL LOCKING DEVICES	
Self-centering	
SIT-LOCK® 3	16 - 17
SIT-LOCK® 4	18 - 19
SIT-LOCK® 4A	20 - 21
SIT-LOCK® 5A	22 - 23
SIT-LOCK® 5B	24 - 25
SIT-LOCK® 6	26 - 27
SIT-LOCK® 7	28 - 29
SIT-LOCK® 8	30 - 31
SIT-LOCK® 12	32 - 33
SIT-LOCK® 15	34 - 35
SIT-LOCK® 16	36 - 37
SIT-LOCK® 18	38 - 39
SIT-LOCK® 13	40 - 41
Not self-centering	
SIT-LOCK® 1	44 - 45
SIT-LOCK® 9	46 - 47
SIT-LOCK® 2	48 - 49
SIT-LOCK® 10 rigid joint	50 - 51
Application examples	52
Customised versions available on request	53 - 54
Application diagram for internal locking devices	55
SHRINK DISCS	
SIT-LOCK® 11	58 ÷ 64
SIT-LOCK® 14	65 ÷ 70
Application examples	71
Customised versions available on request	72 - 73
Application diagram for shrink discs	74
LOCKING DEVICES FOR HIGH BENDING MOMENT	
Introduction	76 - 77
SIT-LOCK® 1	78
SIT-LOCK® 7	79
SIT-LOCK® 4 COMPACT	80

SIT-LOCK® locking device codes

Keyless locking devices	CAL	1	F25	/50
CAL: SIT-LOCK® Keyless locking devices				
Type				
Shaft diameter [mm]				
Outside diameter (hub bore) - [mm]				

NOTE: For external locking devices the d diameter is indicated, not the d_w diameter.

SIT-LOCK® keyless locking device advantages compared to conventional systems

A shaft to hub lock is critical in the design of a mechanical transmission as an unsuitable choice could cause serious damage to the machine or system and result in economic loss. Shaft-hub coupling designs must take several parameters into account:

- assessing application loads: torque, bending moment, axial force, radial force. Stresses that may occur simultaneously;
- alternating loads, sudden starts and stops, very rapid acceleration;
- fatigue limits of the coupling components;
- suitable material use;
- frequent installation and removal requirements;
- fretting corrosion.

As mentioned, coupling breakages could cause high economic damages due to:

- downtime and subsequent production loss;
- damage to other parts of the system;
- material damage to persons or property.

Traditional shaft-hub locking systems include:

- feather keys
- key
- spline coupling
- interference coupling: forced

We assess the features of the traditional systems:

Feather keys

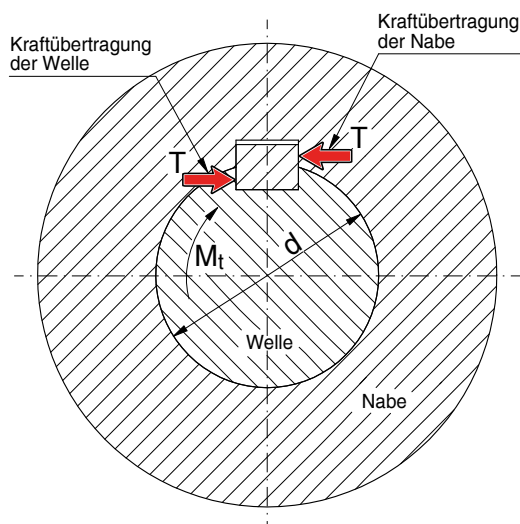

Feather key couplings are the most commonly used, we consider some of the disadvantages:

- high concentration of stress on the shaft and hub due to the high pressure generated on the keyway sides;
- micro-movements caused by the lack of even contact can cause fretting corrosion making it difficult to remove;
- not recommended for alternating loads. Over time, the pressure generated on the keyway sides can widen it and cause the shaft or hub to break. Not recommended in damp environments;

- the lack of contact over the shaft-hub surface may lead to oxidation, making it difficult to remove;
- cannot accept axial loads;
- not recommended for transmissions that require zero backlash;
- significant decrease in shaft strength due to the keyway;
- difficult axial and angular positioning.

Keys

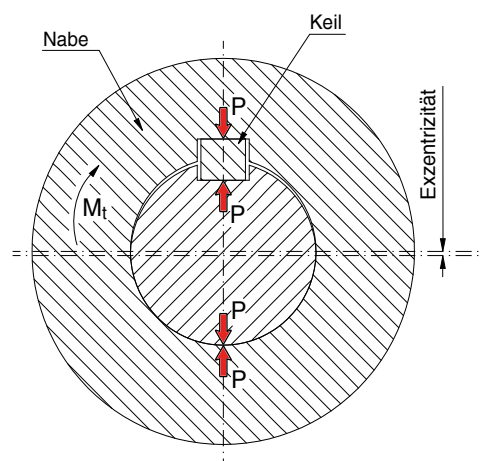

Keyed shaft-hub couplings have the same disadvantages as feather key couplings and also cause significant hub-to-shaft concentricity error.

Splined profile

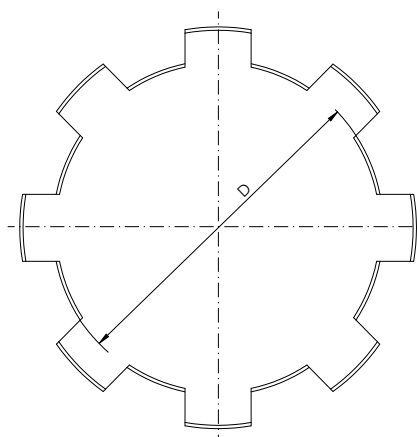

This coupling has the following disadvantages:

- fretting corrosion from the lack of contact making it difficult to remove;
- significant decrease in shaft strength;
- increased cost as it is difficult to make;
- play between shaft and hub;
- difficult angular and axial positioning;
- not recommended in damp or dusty environments. Lack of contact may impair removal.

SIT-LOCK® keyless locking device advantages compared to conventional systems

Interference fit

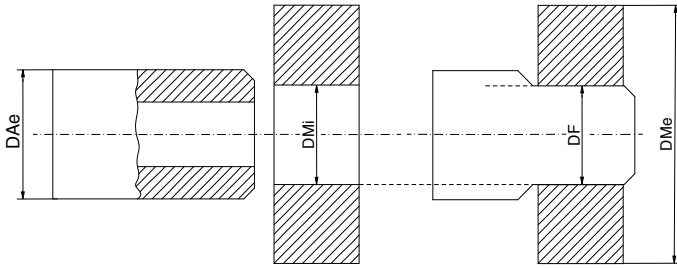

Interference fit shaft-hub connections can be achieved by cooling the shaft or heating the hub. This type of connection is not widely used for the following reasons:

- requires tight tolerances;
- difficult to remove;
- locking area temperature changes;
- the effect of the centrifugal force created by the hub can decrease transmissible torque;
- increased stress concentrated on the edges.

Shaft strength depends on the type of coupling used

As an example, we look at the following data. For a shaft with a diameter d equal to 50 mm, its shaft strength would match the diameter of:

- 39 mm feather key coupling
- 35 mm splined shaft coupling
- 46 mm interference fit
- 49 mm SIT-LOCK® coupling

Note

Incorrect calculations that do not account for all the stresses in a shaft-hub coupling can cause irreparable shaft breakage. Below is an example of fatigue failure caused by shaft-hub locking using a feather key.



SIT-LOCK® locking device coupling

Simply by tightening the screws, SIT-LOCK® keyless locking devices create an axial force on the shaft and the hub that is spread over the entire contact surface. Unlike traditional systems, they offer numerous advantages. The main ones are listed below.

Calculation ease

All the information, transmissible torque, axial force limits, etc., can be found in the catalogue. No additional calculations are required.

Installation and removal

Quick and easy. When installing, the screws simply need to be tightened to the M_s value indicated in the table. For removal, however, the screws need to be loosened evenly. In addition, there are assembly threads that allow the coupled parts to unlock even under extreme conditions.

Shaft and hub tolerances and surface finish

Tight tolerances are not necessary. h8/H8 tolerances are typically used. Some products may allow for h11/H11 tolerances. All the information is available in the catalogue.

Operating temperatures

The values shown in the tables are valid for temperatures from -20 °C to $+200\text{ °C}$. For uses lower or higher than these values, please contact our Technical Department.

Simultaneous loads possible

Using SIT-LOCK® locking devices allows simultaneous torque, axial force, bending moment and radial force. For further information or calculations, please contact our Technical Department.

Increased shaft strength

The shaft has no slots and the pressure generated by tightening the screws does not cause any reduction of the shaft's strength. This enables the diameter of the shaft to be reduced with the same stresses applied, leading to considerable savings on costs.

Easy axial and angular adjustment

Unlike conventional couplings, SIT-LOCK® locking devices simply require placing the hub in the desired position relative to the shaft and tightening the screws.

Oxidation protection

Even in damp environments, the pressures created along the contact surfaces do not allow for oxidation, ensuring easy removal of the locked parts.

No backlash

Connection in transmissions using SIT-LOCK® locking devices are perfectly rigid and there is no backlash that could impair motion transmission or machine precision over time.

Recommended for applications subject to continuous alternating loads

By using SIT-LOCK® locking devices, the stresses generated by alternating or sudden loads are distributed over the entire surface of the shaft and not over a reduced section as occurs with traditional systems.

Formulas for proper SIT-LOCK® locking device use

All the values in the table have been calculated and verified by our Technical Department. All the information for proper use is shown in the table. By tightening the screws to the torque M_s indicated in the table, an axial force P_v occurs which generates a radial force N on the shaft and hub contact surfaces. The pressure generated on the shaft and hub determines the transmissible torque M_t indicated in the table.

Therefore:

$$M_t = N \cdot \mu \cdot \frac{d}{2}$$

The coefficient of friction μ used to calculate the locking device transmissible torque M_t is:

- 0.12 (oiled surfaces) for internal locking devices
- 0.15 (dry surfaces) for external locking devices

This means that for the locking devices with calculated values, with a coefficient of friction μ 0.12, a higher torque can be transmitted without further increasing the screw tightening torque M_s . Our Technical Department is available for further clarifications and calculations.

Avoid using molybdenum disulphide based lubricants or greases on the shaft and hub contact surfaces as this would considerably decrease the friction coefficient μ .

Calculating the minimum hub diameter D_{min}

See the following pages.

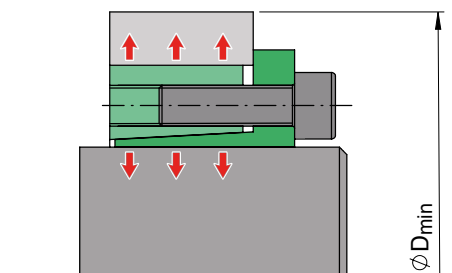

Screw tightening torque M_s

Where necessary, the screw tightening torque M_s can be reduced. As a result, the transmissible torque M_t indicated in the tables decreases proportionally. The same applies to the axial force limits F_{ax} and the pressure generated on the shaft P_w and hub P_n . The tightening torque M_s can be decreased by 30% or 40% of the value indicated in the tables.

Temperature influence

The values in the table are typically valid for applications from -20 °C to +200 °C. In extreme cases, it is possible to use them from -40 °C to +300 °C. For applications subject to high temperatures, we recommend using shafts and hubs with the same coefficient of thermal expansion. For more details, please contact our Technical Department.

Applications with simultaneous torque and axial force

SIT-LOCK® locking devices can simultaneously transmit torque M_t and tolerate an axial force F_{ax} . The table shows the maximum permissible values. Where both values are present simultaneously, the transmissible torque M_t value decreases. Below is the formula for calculating transmissible torque:

$$M_{tam} = \sqrt{M_t^2 + \left(F_{axR} \cdot \frac{d}{2000}\right)^2}$$

- M_{tam} = permissible torque (Nm)
- M_t = torque stated in table (Nm)
- F_{axR} = required axial force (N)
- d = shaft diameter (mm)

Radial force influence

The radial force F_R affects the contact pressure on the shaft and hub generated by the locking device. Radial force generates an increase in pressure P_n generated on the hub. It is highly important to calculate this value as it must be used to verify the minimum hub diameter D_{min} .

$$\Delta P_n = \frac{F_R}{D \cdot H}$$

- ΔP_n = additional pressure on hub (N/mm²)
- F_R = radial force applied (N)
- D = external diameter of the locking device (mm)
- H = locking device outer ring width (mm)

Safety factors

The transmissible torque M_t and tolerable axial force F_{ax} values stated in the catalogue must not be exceeded. The design phase should take any service factors into account.

Applications on shafts with bores

For use on a shaft with a bore corresponding to the pressure P_w , the maximum bore diameter d_B should be:

$$d_B \leq \sqrt{\frac{\sigma_{0,2-1,6} \cdot P_w}{\sigma_{0,2}}} \cdot d$$

The maximum bore d_B will depend on the elastic load $\sigma_{0,2}$ of the shaft material and the surface pressure P_w generated by the locking device (see table values). For hollow shaft applications, locking devices that generate low pressure are recommended.

Calculating the minimum hub diameter D_{min}

To guarantee the torque transmission M_t indicated in the table when using a SIT-LOCK® internal locking device, the screws must be tightened to a specific torque M_s . Tightening the screws creates a pressure on the shaft P_w and on the hub P_n . To calculate the minimum hub diameter D_{min} , the formula generally used for measuring the thickness of thick-walled cylinders subject to high internal pressure is used. The formula for calculating D_{min} is:

$$D_{min} \geq D \cdot K$$

D = outer diameter of the locking device in mm

K = application coefficient

See table below.

The coefficient K is given by the following formula:

$$K = \sqrt{\frac{\sigma_{0,2} + (X \cdot P_n)}{\sigma_{0,2} - (X \cdot P_n)}}$$

Where:

$\sigma_{0,2}$ = hub material elastic limit in N/mm²

X = factor depending on hub shape and width

P_n = surface pressure on the hub

To simplify calculations, our Technical Department has drawn up a table for the coefficient K on the following page.

Example calculation of minimum hub diameter D_{min}

Using the SIT-LOCK® 5B locking device to connect a shaft $d = 50$ mm with a hub made out of a material that has an elastic load $\sigma_{0,2} = 500$ N/mm², and a shape type and hub width equivalent to $X=1$.

From the SIT-LOCK® 5B 50x80 table, the outer diameter D is equal to 80 mm, the pressure P_n on the hub is equal to 70 N/mm². In the table on the next page, by taking the P_n value (70 N/mm²), the X value (1) and of the elastic load $\sigma_{0,2}$ of the hub material (500 N/mm²), coefficient K can be found to be 1.15.

Therefore:

$$D_{min} \geq D \cdot K \geq 80 \cdot 1,15 \geq 92 \text{ mm}$$

APPLICATION A
 $X=1$

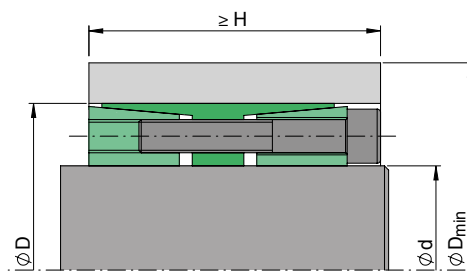
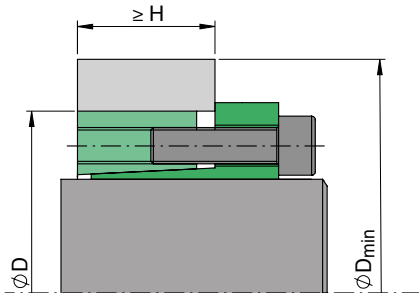

APPLICATION B
 $X=0,8$

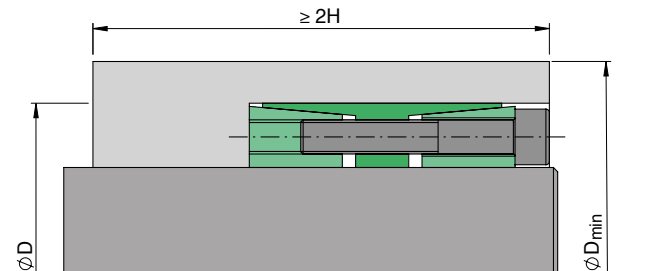
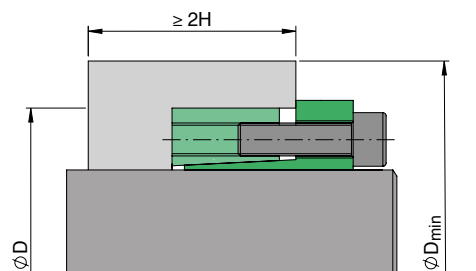

APPLICATION C
 $X=0,6$

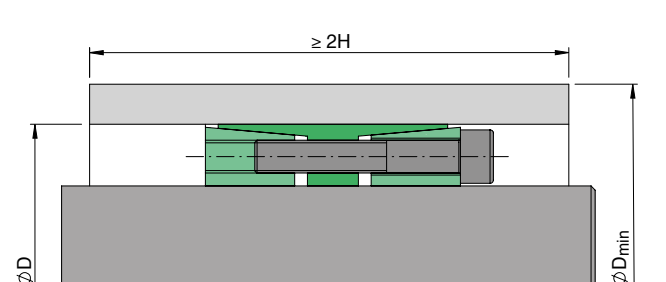
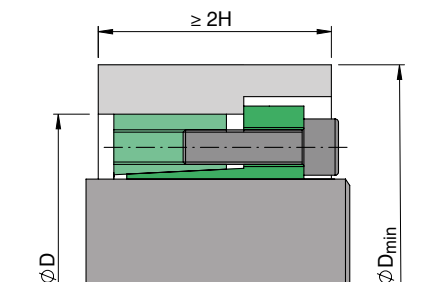

Table of coefficient K

Pressure on hub P_n [N/mm ²]	X factor Application type	Elastic load of hub material $\sigma_{0,2}$ [N/mm ²]											
		150	180	200	220	250	270	300	350	400	450	500	600
		Hub material										Tempering steels	
		GG20	GG25	GG30	GS45	GGG40	St50-2	GGG50	GGG60	GGG70			
			GS38	GTS35	St37-2	GS52	C35	St60-2	St70-2	C60			
50	A X=1	1,41	1,33	1,29	1,26	1,22	1,21	1,18	1,15	1,13	1,12	1,11	1,09
	B X=0,8	1,31	1,25	1,22	1,20	1,18	1,16	1,14	1,12	1,11	1,09	1,08	1,07
	C X=0,6	1,22	1,18	1,16	1,15	1,13	1,12	1,11	1,09	1,08	1,07	1,06	1,05
55	A X=1	1,47	1,37	1,33	1,29	1,25	1,23	1,20	1,17	1,15	1,13	1,12	1,10
	B X=0,8	1,35	1,28	1,25	1,22	1,19	1,18	1,16	1,13	1,12	1,10	1,09	1,08
	C X=0,6	1,25	1,20	1,18	1,16	1,14	1,13	1,12	1,10	1,09	1,08	1,07	1,06
60	A X=1	1,53	1,41	1,36	1,32	1,28	1,25	1,22	1,19	1,16	1,14	1,13	1,11
	B X=0,8	1,39	1,31	1,28	1,25	1,21	1,20	1,18	1,15	1,13	1,11	1,10	1,08
	C X=0,6	1,28	1,22	1,20	1,18	1,16	1,14	1,13	1,11	1,09	1,08	1,07	1,06
65	A X=1	1,59	1,46	1,40	1,36	1,30	1,28	1,25	1,21	1,18	1,16	1,14	1,11
	B X=0,8	1,44	1,35	1,30	1,27	1,24	1,22	1,19	1,16	1,14	1,12	1,11	1,09
	C X=0,6	1,30	1,25	1,22	1,20	1,17	1,16	1,14	1,12	1,10	1,09	1,08	1,07
70	A X=1	1,66	1,51	1,44	1,39	1,33	1,30	1,27	1,22	1,19	1,17	1,15	1,12
	B X=0,8	1,48	1,38	1,33	1,30	1,26	1,23	1,21	1,18	1,15	1,13	1,12	1,10
	C X=0,6	1,33	1,27	1,24	1,21	1,18	1,17	1,15	1,13	1,11	1,10	1,09	1,07
75	A X=1	1,73	1,56	1,48	1,43	1,36	1,33	1,29	1,24	1,21	1,18	1,16	1,13
	B X=0,8	1,53	1,41	1,36	1,32	1,28	1,25	1,22	1,19	1,16	1,14	1,13	1,11
	C X=0,6	1,36	1,29	1,26	1,23	1,20	1,18	1,16	1,14	1,12	1,11	1,09	1,08
80	A X=1	1,81	1,61	1,53	1,46	1,39	1,36	1,31	1,26	1,22	1,20	1,18	1,14
	B X=0,8	1,58	1,45	1,39	1,35	1,30	1,27	1,24	1,20	1,18	1,15	1,14	1,11
	C X=0,6	1,39	1,31	1,28	1,25	1,21	1,20	1,18	1,15	1,13	1,11	1,10	1,08
85	A X=1	1,90	1,67	1,57	1,50	1,42	1,39	1,34	1,28	1,24	1,21	1,19	1,15
	B X=0,8	1,63	1,49	1,42	1,38	1,32	1,29	1,26	1,22	1,19	1,16	1,15	1,12
	C X=0,6	1,42	1,34	1,30	1,27	1,23	1,21	1,19	1,16	1,14	1,12	1,11	1,09
90	A X=1	2,00	1,73	1,62	1,54	1,46	1,41	1,36	1,30	1,26	1,22	1,20	1,16
	B X=0,8	1,69	1,53	1,46	1,40	1,34	1,31	1,28	1,23	1,20	1,18	1,16	1,13
	C X=0,6	1,46	1,36	1,32	1,28	1,25	1,22	1,20	1,17	1,15	1,13	1,11	1,09
95	A X=1	2,11	1,80	1,68	1,59	1,49	1,44	1,39	1,32	1,27	1,24	1,21	1,17
	B X=0,8	1,75	1,57	1,49	1,43	1,37	1,34	1,30	1,25	1,21	1,19	1,17	1,14
	C X=0,6	1,49	1,39	1,34	1,30	1,26	1,24	1,21	1,18	1,15	1,14	1,12	1,10
100	A X=1	2,24	1,87	1,73	1,63	1,53	1,48	1,41	1,34	1,29	1,25	1,22	1,18
	B X=0,8	1,81	1,61	1,53	1,46	1,39	1,36	1,31	1,26	1,22	1,20	1,18	1,14
	C X=0,6	1,53	1,41	1,36	1,32	1,28	1,25	1,22	1,19	1,16	1,14	1,13	1,11
105	A X=1	2,38	1,95	1,79	1,68	1,56	1,51	1,44	1,36	1,31	1,27	1,24	1,19
	B X=0,8	1,88	1,66	1,56	1,50	1,42	1,38	1,33	1,28	1,24	1,21	1,18	1,15
	C X=0,6	1,56	1,44	1,39	1,34	1,29	1,27	1,24	1,20	1,17	1,15	1,14	1,11
110	A X=1	2,55	2,04	1,86	1,73	1,60	1,54	1,47	1,38	1,33	1,28	1,25	1,20
	B X=0,8	1,96	1,71	1,60	1,53	1,44	1,40	1,35	1,29	1,25	1,22	1,19	1,16
	C X=0,6	1,60	1,47	1,41	1,36	1,31	1,28	1,25	1,21	1,18	1,16	1,14	1,12
115	A X=1	2,75	2,13	1,93	1,79	1,64	1,58	1,50	1,41	1,34	1,30	1,26	1,21
	B X=0,8	2,04	1,76	1,64	1,56	1,47	1,43	1,37	1,31	1,26	1,23	1,20	1,17
	C X=0,6	1,64	1,50	1,43	1,38	1,33	1,30	1,26	1,22	1,19	1,17	1,15	1,12
120	A X=1	3,00	2,24	2,00	1,84	1,69	1,61	1,53	1,43	1,36	1,31	1,28	1,22
	B X=0,8	2,13	1,81	1,69	1,60	1,50	1,45	1,39	1,33	1,28	1,24	1,21	1,18
	C X=0,6	1,69	1,53	1,46	1,40	1,34	1,31	1,28	1,23	1,20	1,18	1,16	1,13
125	A X=1	3,32	2,35	2,08	1,91	1,73	1,65	1,56	1,45	1,38	1,33	1,29	1,24
	B X=0,8	2,24	1,87	1,73	1,63	1,53	1,48	1,41	1,34	1,29	1,25	1,22	1,18
	C X=0,6	1,73	1,56	1,48	1,43	1,36	1,33	1,29	1,24	1,21	1,18	1,16	1,13
130	A X=1	3,74	2,49	2,17	1,97	1,78	1,69	1,59	1,48	1,40	1,35	1,30	1,25
	B X=0,8	2,35	1,93	1,78	1,67	1,56	1,50	1,44	1,36	1,30	1,27	1,24	1,19
	C X=0,6	1,78	1,59	1,51	1,45	1,38	1,35	1,30	1,25	1,22	1,19	1,17	1,14
135	A X=1	4,36	2,65	2,27	2,04	1,83	1,73	1,62	1,50	1,42	1,36	1,32	1,26
	B X=0,8	2,48	2,00	1,83	1,71	1,59	1,53	1,46	1,38	1,32	1,28	1,25	1,20
	C X=0,6	1,83	1,62	1,54	1,47	1,40	1,36	1,32	1,27	1,23	1,20	1,18	1,15
140	A X=1	5,39	2,83	2,38	2,12	1,88	1,78	1,66	1,53	1,44	1,38	1,33	1,27
	B X=0,8	2,63	2,07	1,88	1,75	1,62	1,55	1,48	1,39	1,33	1,29	1,26	1,21
	C X=0,6	1,88	1,66	1,56	1,50	1,42	1,38	1,33	1,28	1,24	1,21	1,18	1,15
145	A X=1	7,68	3,05	2,50	2,21	1,94	1,82	1,69	1,55	1,46	1,40	1,35	1,28
	B X=0,8	2,80	2,15	1,94	1,80	1,65	1,58	1,50	1,41	1,35	1,30	1,27	1,22
	C X=0,6	1,94	1,69	1,59	1,52	1,44	1,40	1,35	1,29	1,25	1,22	1,19	1,16
150	A X=1	-	3,32	2,65	2,30	2,00	1,87	1,73	1,58	1,48	1,41	1,36	1,29
	B X=0,8	3,00	2,24	2,00	1,84	1,69	1,61	1,53	1,43	1,36	1,31	1,28	1,22
	C X=0,6	2,00	1,73	1,62	1,54	1,46	1,41	1,36	1,30	1,26	1,22	1,20	1,16
155	A X=1	-	3,66	2,81	2,40	2,06	1,92	1,77	1,61	1,51	1,43	1,38	1,30
	B X=0,8	3,25	2,33	2,06	1,89	1,72	1,64	1,55	1,45	1,38	1,33	1,29	1,23
	C X=0,6	2,06	1,77	1,65	1,57	1,48	1,43	1,38	1,31	1,27	1,23	1,21	1,17
160	A X=1	-	4,12	3,00	2,52	2,13	1,98	1,81	1,64	1,53	1,45	1,39	1,31
	B X=0,8	3,55	2,43	2,13	1,94	1,76	1,67	1,58	1,47	1,39	1,34	1,30	1,24
	C X=0,6	2,13	1,81	1,69	1,60	1,50	1,45	1,39	1,33	1,28	1,24	1,21	1,18
165	A X=1	-	4,80	3,23	2,65	2,21	2,04	1,86	1,67	1,55	1,47	1,41	1,33
	B X=0,8	3,96	2,55	2,21	2,00	1,80	1,71	1,60	1,49	1,41	1,35	1,31	1,25
	C X=0,6	2,21	1,86	1,72	1,62	1,52	1,47	1,41	1,34	1,29	1,25	1,22	1,18

SIT-LOCK® keyless locking device

SIT-LOCK® locking device features - internal

SIT-LOCK® 3

- Self-centering
- Low surface pressures
- Suitable for using on hubs with a low $\sigma_{0.2}$
- Available for shaft diameters of 6 to 130 mm
- No axial displacement when tightening the screws
- Compact dimensions
- Medium to high transmissible torques

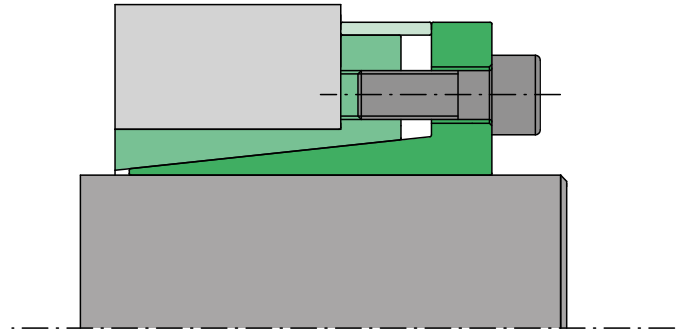

SIT-LOCK® 4, SIT-LOCK® 4A

- Self-centering
- Even pressure distribution
- Very high transmissible torques
- Available for shaft diameters of 25 to 400 mm
- No axial displacement when tightening the screws
- Removal via extraction threads
- Excellent perpendicularity

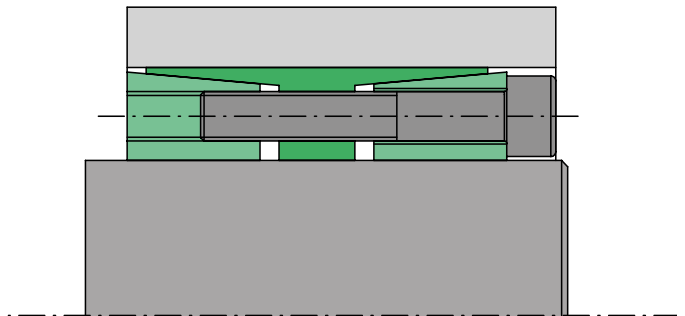

SIT-LOCK® 5A

- Self-centering
- Even pressure distribution
- Available for shaft diameters of 18 to 200 mm
- Axial displacement when tightening screws
- Excellent shaft-to-hub perpendicularity
- High transmissible torques
- Quick installation and removal

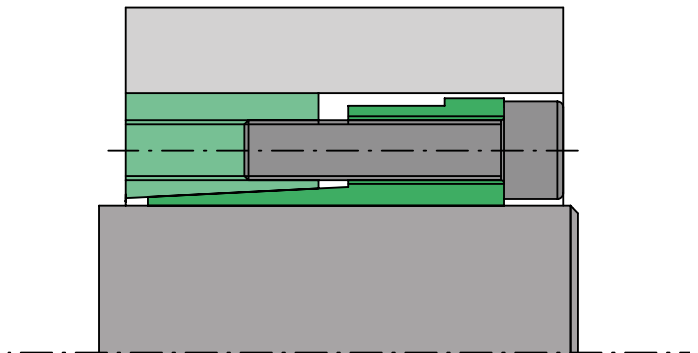

SIT-LOCK® 5B

- Self-centering
- Low surface pressures
- Quick installation and removal
- Available for shaft diameters of 18 to 200 mm
- No axial displacement when tightening the screws
- Excellent shaft-to-hub perpendicularity
- Medium to high transmissible torques

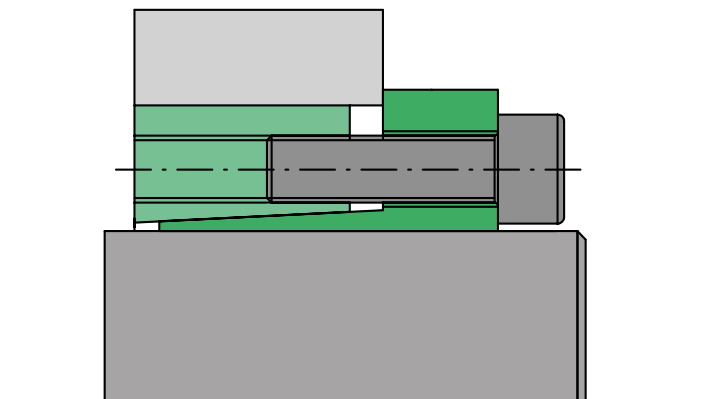

SIT-LOCK® locking device features - internal

SIT-LOCK® 6, SIT-LOCK® 18

- Self-centering
- SIT-LOCK® 6 available for shaft diameters of 18 to 200 mm
- SIT-LOCK® 18 available for shaft diameters of 20 to 70 mm
- Axial displacement when tightening screws
- Optimal shaft-to-hub perpendicularity
- Reduced axial dimensions
- High transmissible torques
- Quick installation and removal



SIT-LOCK® 7

- Self-centering
- Quick installation and removal
- Available for shaft diameters of 18 to 200 mm
- No axial displacement when tightening the screws
- Excellent concentricity and perpendicularity
- Medium to high transmissible torques

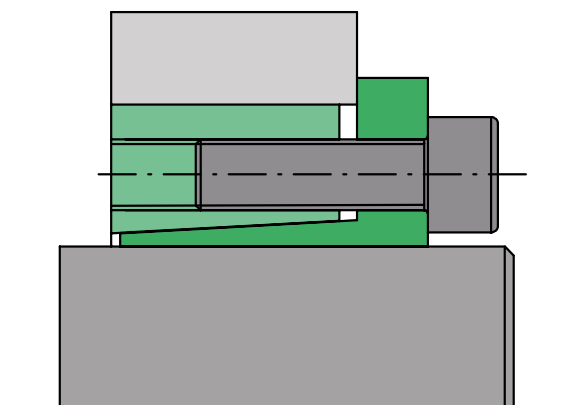

SIT-LOCK® 8

- Self-centering
- Low surface pressures
- Quick installation and removal
- Available for shaft diameters of 14 to 50 mm
- No axial displacement when tightening the screws
- Excellent concentricity and perpendicularity
- Medium to high transmissible torques

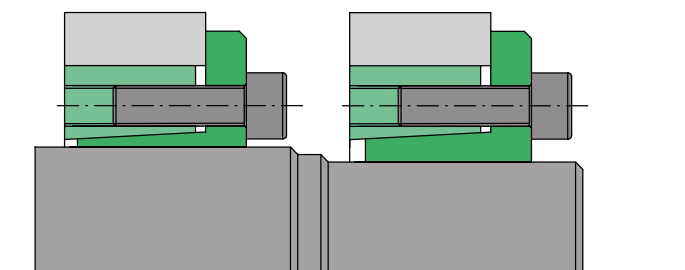

SIT-LOCK® 12

- Self-centering
- Quick installation and removal
- Available for shaft diameters of 18 to 90 mm
- Reduced axial dimensions
- Axial displacement when tightening screws
- Excellent shaft-hub concentricity and perpendicularity
- Medium to high transmissible torques

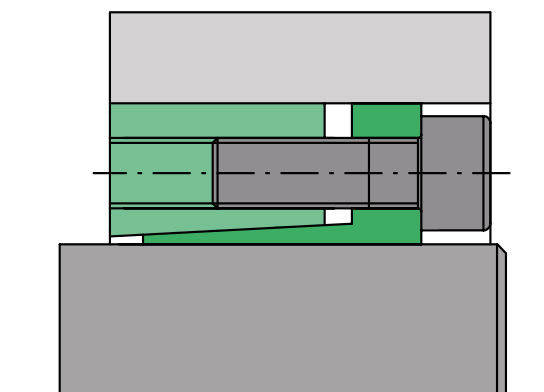

SIT-LOCK® locking device features - internal

SIT-LOCK® 9, SIT-LOCK® 13

- Self-centering (SIT-LOCK® 13)
- Not self-centering (SIT-LOCK® 9)
- Easy installation/removal (SIT-LOCK® 9)
- Available for shaft diameters of 14 a 70 mm
- Axial displacement when tightening the locking nut
- Good perpendicularity (SIT-LOCK® 13)
- Medium to high transmissible torques

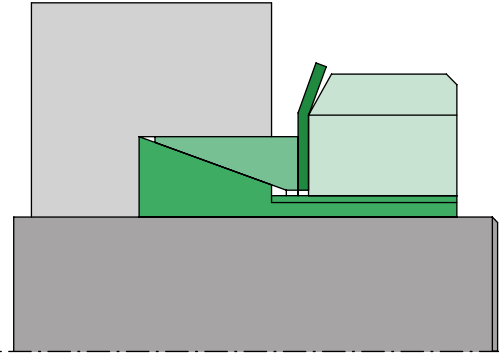

SIT-LOCK® 15

- Self-centering
- Quick installation and removal
- Available for shaft diameters of 5 a 50 mm
- Slight axial displacement when tightening screws
- Excellent shaft-hub concentricity and perpendicularity
- Medium to high transmissible torques
- During assembly, it generates an axial force that can be used to axially clamp bearings or other components adjacent to the hub

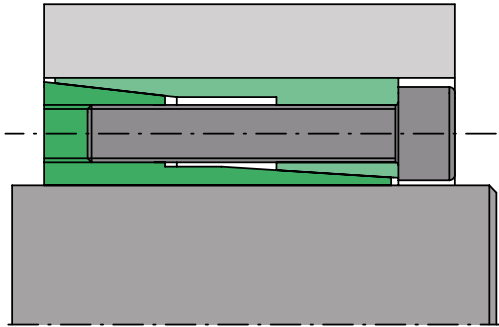

SIT-LOCK® 1

- Not self-centering
- Easy removal
- Available for shaft diameters of 17 a 600 mm
- Long assembly times due to high number of clamping screws
- Possible use on shaft-hubs with large tolerances (h11/H11)
- Easy worldwide availability

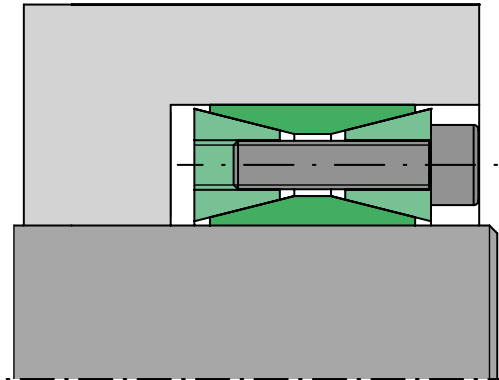

SIT-LOCK® 2

- Not self-centering
- Requires threads in the hub
- Requires a thrust flange
- Quick installation and removal
- Available for shaft diameters of 6 a 240 mm
- No axial displacement during assembly
- Medium to low transmissible torques

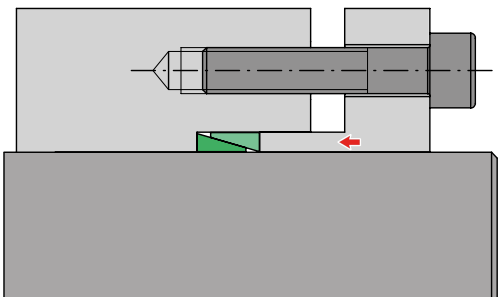

SIT-LOCK® locking device features - internal

SIT-LOCK® 16

- Self-centering
- Effective alternative to SIT-LOCK® 2: no flange or spacer required
- Quick installation and removal
- Available for shaft diameters of 14 to 65 mm
- Tolerance h8 for shaft, H8 for hub
- Axial displacement during assembly
- Medium to high transmissible torques
- Bolts NOT included as their length, being related to end-use, can't be set in advance

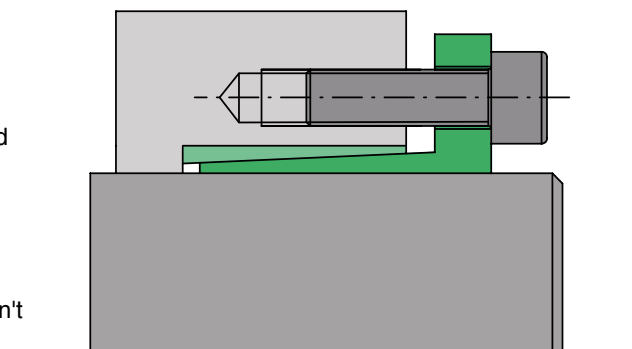

SIT-LOCK® locking device features - rigid joint

SIT-LOCK® 10

- Perfect axial alignment
- No backlash
- Quick installation
- Available for shaft diameters of 17 to 80 mm
- Tolerance h8 for shaft, H8 for hub
- Medium to high transmissible torques

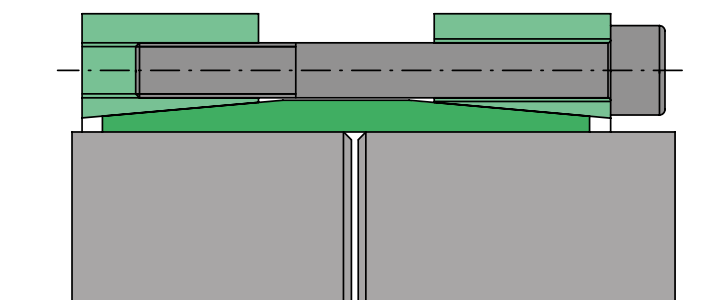

SIT-LOCK® locking device features - shrink disc

SIT-LOCK® 11

- Easy installation/removal
- Available for shaft diameters of 14 to 1000 mm
- High torque
- Four available versions:

SIT-LOCK® 11S	standard series (recommended)
SIT-LOCK® 11S 12.9	SIT-LOCK® 11S with 12.9 screws
SIT-LOCK® 11H	heavy duty series
SIT-LOCK® 11L	lightweight series

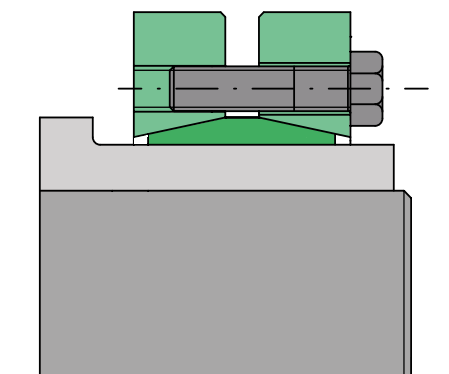

SIT-LOCK® 14

- Quick installation/removal
- Available for shaft diameters of 12 to 1000 mm
- Very high torques
- Five available versions:

SIT-LOCK® 1422	standard series (recommended)
SIT-LOCK® 1481	SIT-LOCK® 1422 with 12.9 screws
SIT-LOCK® 1423	heavy duty series
SIT-LOCK® 1483	SIT-LOCK® 1423 with 12.9 screws
SIT-LOCK® 1421	lightweight series

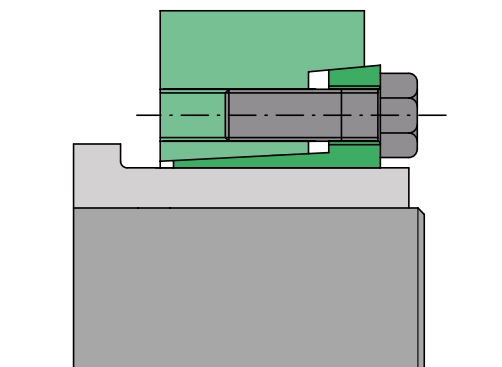

SIT-LOCK® applications



Locking a crusher flywheel using SIT-LOCK® 4.



SIT-LOCK® 5A used for a timing belt pulley.



Locking two shafts using SIT-LOCK® 10, nickel-plated version.



SIT-LOCK® 1 used for a conveyor belt pulley.



Locking the drive pulley of a cable car using SIT-LOCK® 4.



SIT-LOCK® 1422 used to lock a hollow shaft.

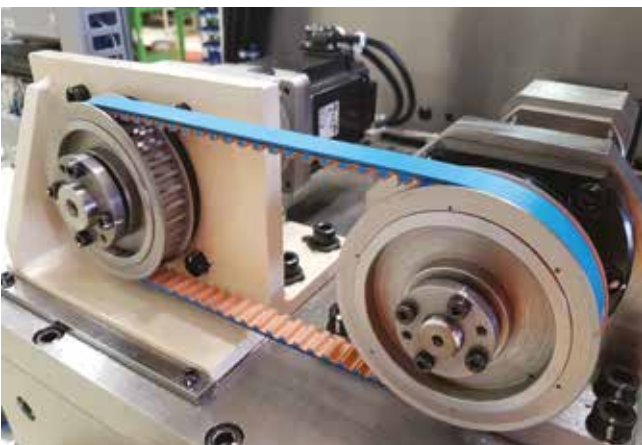

Mounting two pulleys using SIT-LOCK® 3 without spacers.



SIT-LOCK® 3 used for a disc coupling.

SIT-LOCK® applications



Locking the hollow shaft of a planetary gearset using SIT-LOCK® 11.



Locking a bellows coupling using SIT-LOCK® 16.

INTERNAL LOCKING DEVICE - SELF-CENTERING

A background image showing various industrial components, including flanges and bolts, in shades of gray and white.

INTERNAL LOCKING DEVICE SELF-CENTERING

SIT-LOCK® 3 internal locking device - self-centering

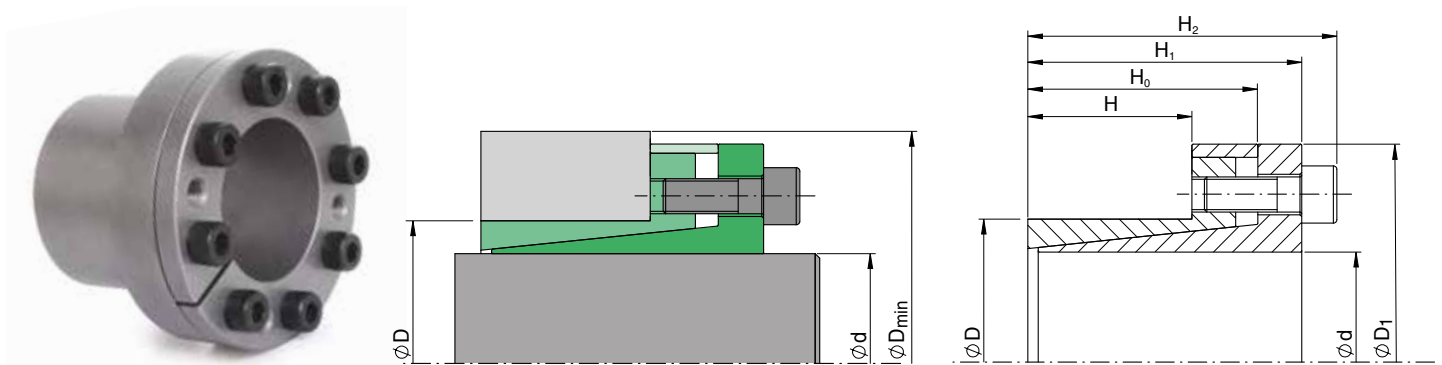

Features

Comprised of a split inner ring and outer ring, and a spacer which prevents the hub from moving relative to the shaft when tightening the screws. This locking device is particularly suitable for applications which require low hub pressures. Recommended for use with aluminium hubs or hubs with lower mechanical properties. The table shows performance data for the following tolerances:

shaft d h8 - coupling seat on hub H8

Do not use molybdenum disulphide-based oils or greases that reduce the coefficient of friction μ . The values in the table are calculated with μ 0.12.

Hub to shaft centering

The SIT-LOCK® 3 locking device is self-centering so it does not require a centering base between the shaft and hub. This allows for hubs with reduced widths which saves on materials and leads to reduced costs.

Installation with non-lubricated surfaces (dry)

The SIT-LOCK® 3 locking device is lubricated with oil before delivery to protect it from oxidation during storage. The values shown in the table have been calculated for applications with oiled contact surfaces. For dry installation, the values are:

$M_t, F_{ax} +5\%$

$P_w, P_n -16\%$

To get these values, the locking device must be completely disassembled and all component surfaces must be cleaned with solvent. The shaft and hub contact surfaces must also be completely clean and oil-free.

Axial displacement

When tightening the screws there is no hub to shaft axial displacement.

Radial loads

The SIT-LOCK® 3 locking device is suitable for applications subject to high radial loads. For further information, please contact our Technical Department.

Surface finish

Normal surface finish is sufficient. The following values are recommended:

$R_a \leq 3,2 \mu\text{m} - R_t \leq 16 \mu\text{m}$

SIT-LOCK® 3 applications without spacer

Using SIT-LOCK® 3 without a flange is not recommended because when the screws are being tightened, there would be a hub to shaft axial displacement. For spacer-free applications, the following installation type is recommended:

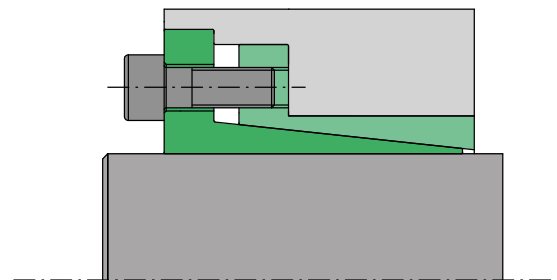

Installation

The locking device is supplied ready to assemble. Clean the shaft contact surfaces thoroughly and apply oil. Mount the shaft, hub and locking device in the desired position.

Screw tightening sequence:

- tighten two diametrically opposed screws until the locking device surfaces make contact with the shaft and hub;
- tighten all screws to 50% of the screw tightening torque value M_s indicated in the table in a 'criss-cross' sequence;
- repeat to 100% of the M_s tightening torque indicated in the table;
- in continuous sequence, check that the tightening torque M_s has been achieved.

Removal

Gradually loosen the clamping screws. Remove the clamping screws and insert them into the special removal threads on the inner ring flange. Tighten the screws in a 'criss-cross' sequence until the locking device is released.

SIT-LOCK® 3 internal locking device - self-centering

Dimensions [mm]						Clamping screws DIN 912 12.9			Values with tolerances for shaft h8/hub H8			
d x D	H	H ₀	H ₁	H ₂	D ₁	Number	Type	M _s [Nm]	M _t [Nm]	F _{ax} [kN]	P _w [N/mm ²]	P _n [N/mm ²]
6 x 14	10	18,5	21	24	25	3	M3	2	11	4	154	65
7 x 15	12	22	25	29	27	3	M4	5	26	8	238	110
8 x 15	12	22	25	29	27	3	M4	5	30	8	209	110
9 x 16	14	23	26	30	28	4	M4	5	45	10	212	120
10 x 16	14	23	26	30	28	4	M4	5	50	10	191	120
11 x 18	14	23	26	30	32	4	M4	5	55	10	173	106
12 x 18	14	23	26	30	32	4	M4	5	60	10	159	105
13 x 23	14	23	26	30	38	4	M4	5	65	10	147	85
14 x 23	14	23	26	30	38	4	M4	5	70	10	136	85
15 x 24	16	29	36	42	45	3	M6	17	128	17	189	120
16 x 24	16	29	36	42	45	3	M6	17	136	17	177	120
17 x 26	18	31	38	44	47	4	M6	17	193	23	197	130
18 x 26	18	31	38	44	47	4	M6	17	205	23	186	130
19 x 27	18	31	38	44	49	4	M6	17	216	23	176	125
20 x 28	18	31	38	44	50	4	M6	17	227	23	168	120
22 x 32	25	38	45	51	54	4	M6	17	250	23	110	75
24 x 34	25	38	45	51	56	4	M6	17	273	23	101	70
25 x 34	25	38	45	51	56	4	M6	17	284	23	97	70
28 x 39	25	38	45	51	61	6	M6	17	478	34	129	95
30 x 41	25	38	45	51	62	6	M6	17	512	34	121	90
32 x 43	25	38	45	51	65	6	M6	17	546	34	113	85
35 x 47	32	45	52	58	69	8	M6	17	796	45	108	80
38 x 50	32	45	52	58	72	8	M6	17	864	45	99	75
40 x 53	32	45	52	58	75	8	M6	17	910	45	94	70
42 x 55	32	45	52	58	78	8	M6	17	955	45	90	70
45 x 59	45	62	70	78	86	8	M8	41	1.891	84	110	85
48 x 62	45	62	70	78	87	8	M8	41	2.017	84	103	80
50 x 65	45	62	70	78	92	8	M8	41	2.101	84	99	75
55 x 71	55	72	80	88	98	9	M8	41	2.600	95	83	65
60 x 77	55	72	80	88	104	9	M8	41	2.836	95	76	60
65 x 84	55	72	80	88	111	9	M8	41	3.073	95	70	55
70 x 90	65	86	96	106	119	9	M10	83	5.254	150	88	70
75 x 95	65	86	96	106	126	9	M10	83	5.630	150	82	65
80 x 100	65	86	96	106	131	12	M10	83	8.006	200	102	80
85 x 106	65	86	96	106	137	12	M10	83	8.507	200	96	80
90 x 112	65	86	96	106	144	12	M10	83	9.007	200	91	75
95 x 120	65	86	96	106	149	14	M10	83	11.092	234	100	80
100 x 125	65	86	96	106	154	18	M10	83	15.012	300	123	100
110 x 140	90	114	128	140	180	12	M12	145	16.029	291	78	60
120 x 155	90	114	128	140	198	12	M12	145	17.486	291	72	55
130 x 165	90	114	128	140	208	16	M12	145	25.257	389	88	70

M _s	Screw tightening torque	Nm
M _t	Transmissible torque	Nm
F _{ax}	Transmissible axial force	kN
P _w	Pressure on shaft	N/mm ²
P _n	Pressure on hub	N/mm ²

IMPORTANT: The screw tightening torque M_s can be reduced by 40% of the value indicated in the table. M_t, F_{ax}, P_w, P_n decrease proportionally. For further information, please contact our Technical Department.

For larger diameters or dimensions different to those in the table, please contact us.

SIT-LOCK® 4 internal locking device - self-centering

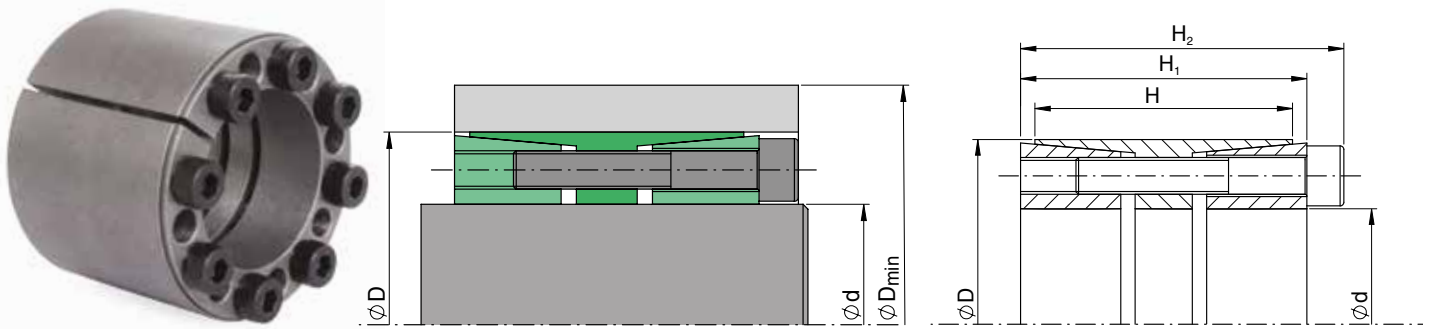

Features

Composed of two tapered rings and one outer ring with a split. It is particularly suitable for applications that require high torque transmission. The table shows performance data for the following tolerances:

shaft d h8 - coupling seat on hub H8

Do not use molybdenum disulphide-based oils or greases that reduce the coefficient of friction μ . The values in the table are calculated with μ 0.12.

Hub to shaft centering

The SIT-LOCK® 4 locking device is self-centering so it does not require a centering base between the shaft and hub. This allows for hubs with reduced widths which saves on materials and leads to reduced costs.

Installation with non-lubricated surfaces (dry)

The SIT-LOCK® 4 locking device is lubricated with oil before delivery to protect it from oxidation during storage. The values shown in the table have been calculated for applications with oiled contact surfaces. For dry installation, the values are:

$M_t, F_{ax} +5\%$

$P_w, P_n -16\%$

To get these values, the locking device must be completely disassembled and all component surfaces must be cleaned with solvent. The shaft and hub contact surfaces must also be completely dry.

Axial displacement

When tightening the screws there is no hub to shaft axial displacement.

Radial loads

The SIT-LOCK® 4 locking device is suitable for high radial loads. For further information, please contact our Technical Department.

Surface finish

Normal surface finish is sufficient. The following values are recommended:

$R_a \leq 3,2 \mu\text{m} - R_t \leq 16 \mu\text{m}$

Applications with more than one SIT-LOCK® 4 device

Where two SIT-LOCK® 4 locking devices are mounted in a row, the total transmissible torque M_t is:

1 device $M_t = M_t$ indicated in catalogue

2 devices $M_t = M_t$ indicated in catalogue $\cdot 1.9$

Installation

The locking device is supplied ready to assemble. Clean the shaft contact surfaces thoroughly and apply oil. Mount the shaft, hub and locking device in the desired position.

Screw tightening sequence:

- tighten four screws crosswise until the locking device surfaces make contact with the shaft and hub;
- tighten all screws to 50% of the screw tightening torque value M_s indicated in the table in a 'criss-cross' sequence;
- repeat to 100% of the M_s tightening torque indicated in the table;
- in continuous sequence, check that the tightening torque M_s has been achieved. Installation is complete when all screws are tightened to the M_s tightening torque indicated in the table.

Removal

- gradually loosen the clamping screws and remove them from the locking device;
- insert the screws into the front tapered bush removal threads and tighten them in a 'criss-cross' sequence until the front cone is completely removed. Do not tighten the screws to a value greater than the M_s tightening torque indicated in the table;
- insert the screws into the extraction threads of the outer ring's central flange and tighten them in a 'criss-cross' sequence until the rear tapered bush is fully removed. Do not tighten the screws to a value greater than the M_s tightening torque indicated in the table.

Reusing the locking device

When reusing the locking device, check all the surfaces are clean and show no obvious signs of deformation or seizing. Oil all surfaces and threads. Check the screws have not been deformed. Oil the screws and reinstall the components in their original places.

SIT-LOCK® 4 internal locking device - self-centering

Dimensions [mm]				Clamping screws DIN 912 12.9			Values with tolerances for shaft h8/hub H8				
d x D	H	H ₁	H ₂	Number	Type	M _s [Nm]	M _t [Nm]	F _{ax} [kN]	P _w [N/mm ²]	P _n [N/mm ²]	
25 x 50	41	45	51	6	M6	17	849	68	176	85	
28 x 55	41	45	51	8	M6	17	1.268	90	209	105	
30 x 55	41	45	51	8	M6	17	1.358	90	195	105	
35 x 60	41	45	51	8	M6	17	1.585	90	167	95	
38 x 65	41	45	51	8	M6	17	1.721	90	154	90	
40 x 65	41	45	51	10	M6	17	2.264	113	183	110	
42 x 75	41	45	53	8	M8	41	3.514	167	258	140	
45 x 75	41	45	53	8	M8	41	3.888	167	130	150	
48 x 80	58	62	70	8	M8	41	4.016	167	159	95	
50 x 80	58	62	70	8	M8	41	4.183	167	153	95	
55 x 85	58	62	70	8	M8	41	4.602	167	139	90	
60 x 90	58	62	70	10	M8	41	6.275	209	159	105	
65 x 95	58	62	70	10	M8	41	6.798	209	147	100	
70 x 110	70	76	86	10	M10	83	11.624	332	180	110	
75 x 115	70	76	86	10	M10	83	12.455	332	168	105	
80 x 120	70	76	86	12	M10	83	15.942	399	189	125	
85 x 125	70	76	86	12	M10	83	16.938	399	178	120	
90 x 130	70	76	86	12	M10	83	17.935	399	168	115	
95 x 135	70	76	86	12	M10	83	18.931	399	159	110	
100 x 145	92	98	110	12	M12	145	29.014	580	167	115	
110 x 155	92	98	110	12	M12	145	34.575	629	165	115	
120 x 165	92	98	110	14	M12	145	40.620	677	163	115	
130 x 180	108	114	128	12	M14	230	51.753	796	150	105	
140 x 190	108	114	128	14	M14	230	65.023	929	163	115	
150 x 200	108	114	128	16	M14	230	79.620	1.062	174	125	
160 x 210	108	146	162	16	M14	230	84.928	1.062	163	120	
170 x 225	136	146	162	14	M16	355	109.736	1.291	148	110	
180 x 235	136	146	162	16	M16	355	132.790	1.475	160	120	
190 x 250	136	146	162	16	M16	355	140.167	1.475	151	115	
200 x 260	136	146	162	16	M16	355	147.544	1.475	144	110	
220 x 285	136	146	162	20	M16	355	202.873	1.844	164	125	
240 x 305	136	146	162	22	M16	355	243.448	2.028	165	125	
260 x 325	136	146	162	22	M16	355	263.735	2.028	152	120	
280 x 355	138	148	168	20	M20	690	403.047	2.878	198	125	
300 x 375	165	177	197	22	M20	690	475.020	3.166	170	135	
320 x 405	165	177	197	22	M20	690	506.688	3.166	159	125	
340 x 425	165	177	197	24	M20	690	587.297	3.454	163	130	
360 x 455	188	202	224	22	M22	930	709.561	3.492	154	120	
380 x 475	188	202	224	26	M22	930	885.159	4.658	173	135	
400 x 495	188	202	224	26	M22	930	931.746	4.658	164	130	

M _s	Screw tightening torque	Nm
M _t	Transmissible torque	Nm
F _{ax}	Transmissible axial force	kN
P _w	Pressure on shaft	N/mm ²
P _n	Pressure on hub	N/mm ²

IMPORTANT: The screw tightening torque M_s can be reduced by 40% of the value indicated in the table. M_t, F_{ax}, P_w, P_n decrease proportionally. For further information, please contact our Technical Department.

For larger diameters or dimensions different to those in the table, please contact us.

SIT-LOCK® 4A internal locking device - self-centering

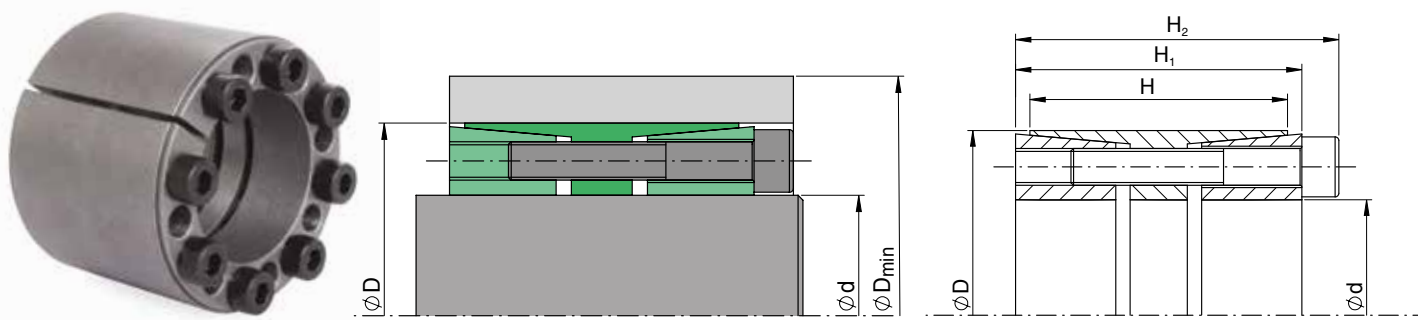

Features

Composed of two tapered rings and one outer ring with a split. It is particularly suitable for applications that require high torque transmission. The table shows performance data for the following tolerances:

shaft d h8 - coupling seat on hub H8

Do not use molybdenum disulphide-based oils or greases that reduce the coefficient of friction μ . The values in the table are calculated with μ 0.12.

Hub to shaft centering

The SIT-LOCK® 4A locking device is self-centering so it does not require a centering base between the shaft and hub. This allows for hubs with reduced widths which saves on materials and leads to reduced costs.

Installation with non-lubricated surfaces (dry)

The SIT-LOCK® 4A locking device is lubricated with oil before delivery to protect it from oxidation during storage. The values shown in the table have been calculated for applications with oiled contact surfaces. For dry installation, the values are:

$M_t, F_{ax} +5\%$

$P_w, P_n -16\%$

To get these values, the locking device must be completely disassembled and all component surfaces must be cleaned with solvent. The shaft and hub contact surfaces must also be completely dry.

Axial displacement

When tightening the screws there is no hub to shaft axial displacement.

Radial loads

The SIT-LOCK® 4A locking device is suitable for high radial loads. For further information, please contact our Technical Department.

Surface finish

Normal surface finish is sufficient. The following values are recommended:

$R_a \leq 3,2 \mu\text{m} - R_t \leq 16 \mu\text{m}$

Applications with more than one SIT-LOCK® 4A device

Where two SIT-LOCK® 4A locking devices are mounted in a row, the total transmissible torque M_t is:

2 devices $M_t = M_t$ indicated in catalogue $\cdot 1,9$

Installation

The locking device is supplied ready to assemble. Clean the shaft contact surfaces thoroughly and apply oil. Mount the shaft, hub and locking device in the desired position.

Screw tightening sequence:

- tighten four screws crosswise until the locking device surfaces make contact with the shaft and hub;
- tighten all screws to 50% of the screw tightening torque value M_s indicated in the table in a 'criss-cross' sequence;
- repeat to 100% of the M_s tightening torque indicated in the table;
- in continuous sequence, check that the tightening torque M_s has been achieved. Installation is complete when all screws are tightened to the M_s tightening torque indicated in the table.
-

Removal

- gradually loosen the clamping screws and remove them from the locking device;
- insert the screws into the front tapered bush removal threads and tighten them in a 'criss-cross' sequence until the front tapered bush is completely removed. Do not tighten the screws to a value greater than the M_s tightening torque indicated in the table;
- insert the screws into the extraction threads of the outer ring's central flange and tighten them in a 'criss-cross' sequence until the rear tapered bush is fully removed. Do not tighten the screws to a value greater than the M_s tightening torque indicated in the table.

Reusing the locking device

When reusing the locking device, check all the surfaces are clean and show no obvious signs of deformation or seizing. Oil all surfaces and the inside of the threads. Check the screws have not been deformed. Oil the screws and reinstall the components in their original places.

SIT-LOCK® 4A internal locking device - self-centering

Dimensions [mm]				Clamping screws DIN 912 12.9			Values with tolerances for shaft h8/hub H8				
d x D	H	H ₁	H ₂	Number	Type	M _s [Nm]	M _t [Nm]	F _{ax} [kN]	P _w [N/mm ²]	P _n [N/mm ²]	
25 x 55	32	40	46	6	M6	17	877	70	286	105	
28 x 55	32	40	46	6	M6	17	982	70	256	105	
30 x 55	32	40	46	6	M6	17	1.052	70	239	105	
35 x 60	44	54	60	7	M6	17	1.432	82	163	80	
38 x 75	44	54	62	7	M8	41	2.873	151	278	120	
40 x 75	44	54	62	7	M8	41	3.025	151	264	120	
42 x 75	44	54	62	7	M8	41	3.176	151	265	120	
45 x 75	44	54	62	7	M8	41	3.403	151	235	120	
48 x 80	56	64	72	8	M8	41	4.148	173	199	100	
50 x 80	56	64	72	8	M8	41	4.321	173	191	100	
55 x 85	56	64	72	9	M8	41	5.347	194	195	110	
60 x 90	56	64	72	10	M8	41	6.482	216	199	115	
65 x 95	56	64	72	10	M8	41	7.022	216	184	110	

From diameters of 70 mm, SIT-LOCK® 4A is the same as SIT-LOCK® 4.
For SIT-LOCK® 4 dimensions and performance, refer to the table on page 19.

M _s	Screw tightening torque	Nm
M _t	Transmissible torque	Nm
F _{ax}	Transmissible axial force	kN
P _w	Pressure on shaft	N/mm ²
P _n	Pressure on hub	N/mm ²

IMPORTANT: The screw tightening torque M_s can be reduced by 40% of the value indicated in the table. M_t, F_{ax}, P_w, P_n decrease proportionally.
For further information, please contact our Technical Department.

For larger diameters or dimensions different to those in the table, please contact us.

SIT-LOCK® 5A internal locking device - self-centering

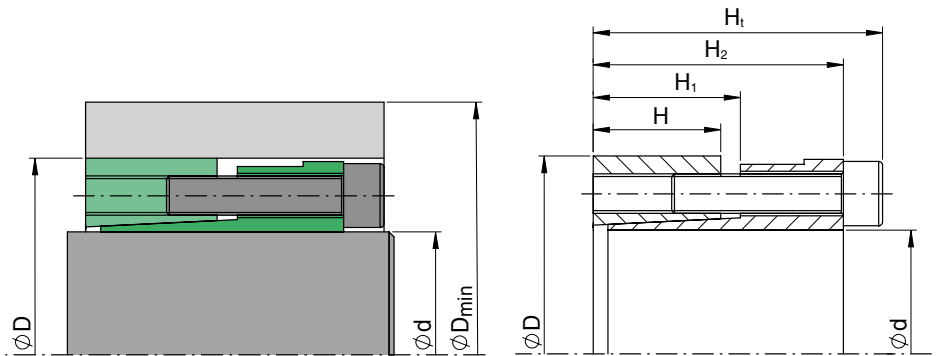

Features

Composed of an inner ring and outer ring both with splits. This type of locking device is particularly suitable for applications that require excellent hub-to-shaft concentricity and perpendicularity. The table shows performance data for the following tolerances:

shaft d h8 - coupling seat on hub H8

Do not use molybdenum disulphide-based oils or greases that reduce the coefficient of friction μ . The values in the table are calculated with μ 0.12.

Hub to shaft centering

The SIT-LOCK® 5A locking device is self-centering so it does not require a centering base between the shaft and hub. This allows for hubs with reduced widths which saves on materials and leads to reduced costs.

Installation with non-lubricated surfaces (dry)

The SIT-LOCK® 5A locking device is lubricated with oil before delivery to protect it from oxidation during storage. The values shown in the table have been calculated for applications with oiled contact surfaces. For dry installation, the values are:

$$M_t, F_{ax} +8\%$$

$$P_w, P_n -13\%$$

To get these values, the locking device must be completely disassembled and all its component surfaces must be cleaned with solvent. The shaft and hub contact surfaces must also be completely clean and oil-free.

Axial displacement

When tightening the screws there is a hub to shaft axial displacement. The extent of axial displacement depends on the tolerances.

Radial loads

SIT-LOCK® 5A is suitable for use with applications subject to high radial loads. For further information, please contact our Technical Department.

Surface finish

Normal surface finish is sufficient. The following values are recommended:

$$R_a \leq 3,2 \mu\text{m} - R_t \leq 16 \mu\text{m}$$

Installation

The locking device is supplied ready to assemble. Clean the shaft contact surfaces thoroughly and apply oil. Mount the shaft, hub and locking device in the desired position.

Screw tightening sequence:

- tighten two diametrically opposed screws until the locking device surfaces make contact with the shaft and hub;
- tighten all screws to 50% of the screw tightening torque value M_s indicated in the table in a 'criss-cross' sequence;
- repeat to 100% of the M_s tightening torque indicated in the table;
- in continuous sequence, check that the tightening torque M_s has been achieved.

Removal

Gradually loosen the clamping screws. Remove the clamping screws and insert them into the special removal threads on the inner ring flange.

Tighten the screws in a 'criss-cross' sequence until the locking device is released.

Reusing the locking device

When reusing the locking device, check all the surfaces are clean and show no obvious signs of deformation or seizing. Clean and oil all surfaces and threads. Check the screws have not been deformed. Oil the screws and assemble the locking device as originally supplied.

SIT-LOCK® 5A internal locking device - self-centering

Dimensions [mm]					Clamping screws DIN 912 12.9			Values with tolerances for shaft h8/hub H8			
d x D	H _t	H ₂	H ₁	H	Number	Type	M _s [Nm]	M _t [Nm]	F _{ax} [kN]	P _w [N/mm ²]	P _n [N/mm ²]
18 x 47	48	42	29	26	6	M6	17	492	55	310	120
19 x 47	48	42	29	26	6	M6	17	520	55	294	120
20 x 47	48	42	29	26	6	M6	17	547	55	279	120
22 x 47	48	42	29	26	6	M6	17	602	55	254	120
24 x 50	48	42	29	26	6	M6	17	657	55	233	110
25 x 50	48	42	29	26	6	M6	17	684	55	223	110
28 x 55	48	42	29	26	6	M6	17	766	55	199	100
30 x 55	48	42	29	26	6	M6	17	821	55	186	100
32 x 60	48	42	29	26	9	M6	17	1.313	82	262	140
35 x 60	48	42	29	26	9	M6	17	1.436	82	239	140
38 x 65	48	42	29	26	9	M6	17	1.559	82	220	130
40 x 65	48	42	29	26	9	M6	17	1.641	82	209	130
42 x 75	59	51	34	30	6	M8	41	2.123	101	213	120
45 x 75	59	51	34	30	6	M8	41	2.275	101	199	120
48 x 80	59	51	34	30	6	M8	41	2.426	101	186	110
50 x 80	59	51	34	30	6	M8	41	2.527	101	179	110
55 x 85	59	51	34	30	9	M8	41	4.170	152	244	160
60 x 90	59	51	34	30	9	M8	41	4.549	152	223	150
65 x 95	59	51	34	30	9	M8	41	4.928	152	206	140
70 x 110	66	56	45	40	7	M10	83	6.555	187	177	115
75 x 115	66	56	45	40	7	M10	83	7.023	187	166	110
80 x 120	66	56	45	40	7	M10	83	7.491	187	155	105
85 x 125	66	56	45	40	8	M10	83	9.096	214	167	115
90 x 130	66	56	45	40	8	M10	83	9.631	214	158	110
95 x 135	66	56	45	40	10	M10	83	12.708	268	187	130
100 x 145	77	65	52	45	7	M12	145	13.634	273	161	110
110 x 155	77	65	52	45	8	M12	145	17.931	326	175	125
120 x 165	77	65	52	45	10	M12	145	24.450	408	200	145
130 x 180	77	65	52	45	12	M12	145	31.787	489	222	160
140 x 190	88	74	59	50	10	M14	230	39.141	559	212	155
150 x 200	88	74	59	50	12	M14	230	50.325	671	237	180
160 x 210	88	74	59	50	12	M14	230	53.680	671	222	170
170 x 225	88	74	59	50	14	M14	230	66.540	783	244	185
180 x 235	88	74	59	50	14	M14	230	70.455	783	231	175
190 x 250	88	74	59	50	15	M14	230	79.681	839	234	180
200 x 260	88	74	59	50	17	M14	230	95.058	951	252	195

M _s	Screw tightening torque	Nm
M _t	Transmissible torque	Nm
F _{ax}	Transmissible axial force	kN
P _w	Pressure on shaft	N/mm ²
P _n	Pressure on hub	N/mm ²

IMPORTANT: The screw tightening torque M_s can be reduced by 40% of the value indicated in the table. M_t, F_{ax}, P_w, P_n decrease proportionally. For further information, please contact our Technical Department.

For larger diameters or dimensions different to those in the table, please contact us.

SIT-LOCK® 5B internal locking device - self-centering

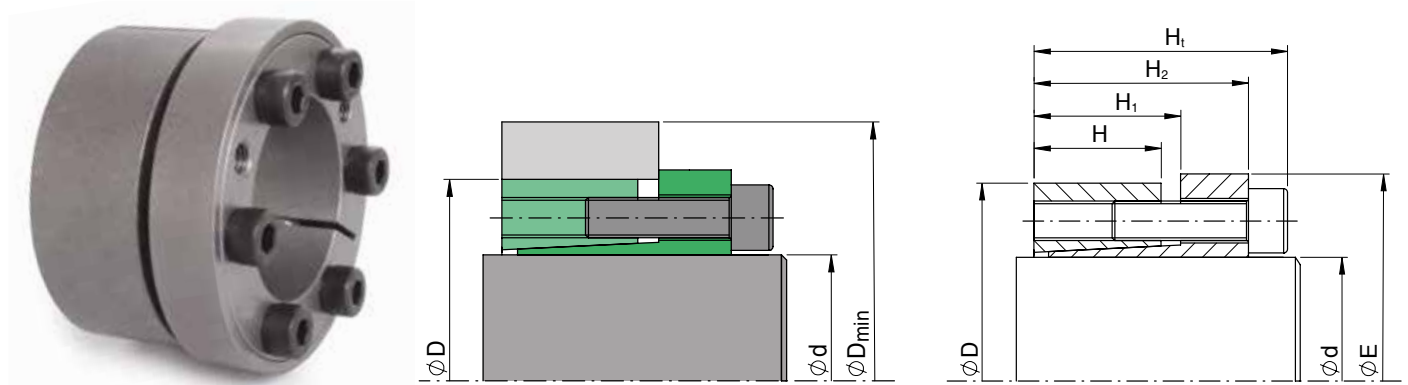

Features

Composed of an inner ring and outer ring both with splits. This type of locking device is particularly suitable for applications that require excellent hub-to-shaft concentricity and perpendicularity. It is also used for locking hubs with lower mechanical properties. The table shows performance data for the following tolerances:

shaft d h8 - coupling seat on hub H8

Do not use molybdenum disulphide-based oils or greases that reduce the coefficient of friction μ . The values in the table are calculated with μ 0.12.

Hub to shaft centering

The SIT-LOCK® 5B locking device is self-centering so it does not require a centering base between the shaft and hub. This allows for hubs with reduced widths which saves on materials and leads to reduced costs.

Installation with non-lubricated surfaces (dry)

The SIT-LOCK® 5B locking device is lubricated with oil before delivery to protect it from oxidation during storage. The values shown in the table have been calculated for applications with oiled contact surfaces. For dry installation, the values are:

$M_t, F_{ax} +5\%$

$P_w, P_n -16\%$

To get these values, the locking device must be completely disassembled and all its component surfaces must be cleaned with solvent. The shaft and hub contact surfaces must also be completely clean and oil-free.

Axial displacement

When tightening the screws there is no hub to shaft axial displacement.

Radial loads

SIT-LOCK® 5B is suitable for use with applications subject to high radial loads. For further information, please contact our Technical Department.

Surface finish

Normal surface finish is sufficient. The following values are recommended:

$R_a \leq 3,2 \mu\text{m} - R_t \leq 16 \mu\text{m}$

Installation

The locking device is supplied ready to assemble. Clean the shaft contact surfaces thoroughly and apply oil. Mount the shaft, hub and locking device in the desired position.

Screw tightening sequence:

- tighten two diametrically opposed screws until the locking device surfaces make contact with the shaft and hub;
- tighten all screws to 50% of the screw tightening torque value M_s indicated in the table in a 'criss-cross' sequence;
- repeat to 100% of the M_s tightening torque indicated in the table;
- in continuous sequence, check that the tightening torque M_s has been achieved.

Removal

Gradually loosen the clamping screws. Remove the clamping screws and insert them into the special removal threads on the inner ring flange.

Tighten the screws in a 'criss-cross' sequence until the locking device is released.

Reusing the locking device

When reusing the locking device, check all the surfaces are clean and show no obvious signs of deformation or seizing. Clean and oil all surfaces and threads. Check the screws have not been deformed. Oil the screws and assemble the locking device as originally supplied.

SIT-LOCK® 5B stop ring

The stop ring, which prevents the hub from moving, is also available in different widths or integrated with the inner ring flange. The locking device is guaranteed to function in either case.

SIT-LOCK® 5B internal locking device - self-centering

Dimensions [mm]						Clamping screws DIN 912 12.9			Values with tolerances for shaft h8/hub H8			
d x D	H _t	H ₂	H ₁	H	E	Number	Type	M _s [Nm]	M _t [Nm]	F _{ax} [kN]	P _w [N/mm ²]	P _n [N/mm ²]
18 x 47	48	42	29	26	53	6	M6	17	307	34	193	75
19 x 47	48	42	29	26	53	6	M6	17	324	34	183	75
20 x 47	48	42	29	26	53	6	M6	17	341	34	174	75
22 x 47	48	42	29	26	53	6	M6	17	375	34	158	75
24 x 50	48	42	29	26	56	6	M6	17	409	34	145	70
25 x 50	48	42	29	26	56	6	M6	17	426	34	139	70
28 x 55	48	42	29	26	61	6	M6	17	478	34	124	65
30 x 55	48	42	29	26	61	6	M6	17	512	34	116	65
32 x 60	48	42	29	26	66	9	M6	17	819	51	163	87
35 x 60	48	42	29	26	66	9	M6	17	895	51	149	85
38 x 65	48	42	29	26	71	9	M6	17	972	51	137	80
40 x 65	48	42	29	26	71	9	M6	17	1.023	51	131	80
42 x 75	59	51	34	30	81	6	M8	41	1.324	63	133	75
45 x 75	59	51	34	30	81	6	M8	41	1.418	63	124	75
48 x 80	59	51	34	30	86	6	M8	41	1.513	63	116	70
50 x 80	59	51	34	30	86	6	M8	41	1.576	63	111	70
55 x 85	59	51	34	30	91	9	M8	41	2.600	95	152	100
60 x 90	59	51	34	30	96	9	M8	41	2.836	95	139	95
65 x 95	59	51	34	30	102	9	M8	41	3.073	95	129	90
70 x 110	66	56	45	40	117	7	M10	83	4.087	117	111	70
75 x 115	66	56	45	40	122	7	M10	83	4.379	117	103	65
80 x 120	66	56	45	40	127	7	M10	83	4.670	117	97	65
85 x 125	66	56	45	40	132	8	M10	83	5.671	133	104	70
90 x 130	66	56	45	40	137	8	M10	83	6.005	133	98	70
95 x 135	66	56	45	40	142	10	M10	83	7.923	167	116	80
100 x 145	77	65	52	46	153	7	M12	145	8.500	170	98	70
110 x 155	77	65	52	46	163	8	M12	145	1.0990	200	105	75
120 x 165	77	65	52	46	173	10	M12	145	14.984	250	120	85
130 x 180	77	65	52	46	188	12	M12	145	19.479	300	135	95
140 x 190	88	74	59	51	199	10	M14	230	23.986	343	127	95
150 x 200	88	74	59	51	209	12	M14	230	30.840	411	143	105
160 x 210	88	74	59	51	219	12	M14	230	32.896	441	134	100
170 x 225	88	74	59	51	234	14	M14	230	40.777	480	147	110
180 x 235	88	74	59	51	244	14	M14	230	43.175	480	139	105
190 x 250	88	74	59	51	234	15	M14	230	48.829	514	141	105
200 x 260	88	74	59	51	244	15	M14	230	51.399	514	134	105

M _s	Screw tightening torque	Nm
M _t	Transmissible torque	Nm
F _{ax}	Transmissible axial force	kN
P _w	Pressure on shaft	N/mm ²
P _n	Pressure on hub	N/mm ²

IMPORTANT: The screw tightening torque M_s can be reduced by 40% of the value indicated in the table. M_t, F_{ax}, P_w, P_n decrease proportionally. For further information, please contact our Technical Department.

For larger diameters or dimensions different to those in the table, please contact us.

SIT-LOCK® 6 internal locking device - self-centering

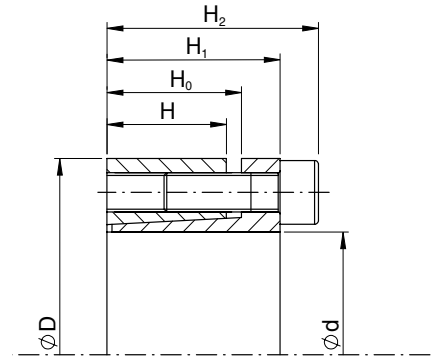
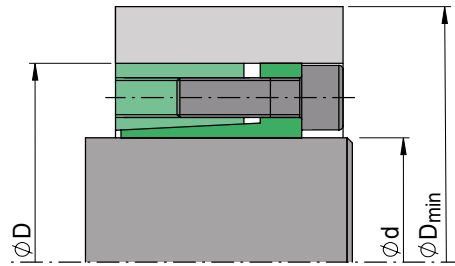

Features

Composed of an inner ring and outer ring both with splits. This type of locking device is particularly suitable for applications that require good hub-to-shaft concentricity and perpendicularity. The table shows performance data for the following tolerances:

shaft d h8 - coupling seat on hub H8

Do not use molybdenum disulphide-based oils or greases that reduce the coefficient of friction μ . The values in the table are calculated with μ 0.12.

Hub to shaft centering

The SIT-LOCK® 6 locking device is self-centering so it does not require a centering base between the shaft and hub. This allows for hubs with reduced widths which saves on materials and leads to reduced costs.

Installation with non-lubricated surfaces (dry)

The SIT-LOCK® 6 locking device is lubricated with oil before delivery to protect it from oxidation during storage. The values shown in the table have been calculated for applications with oiled contact surfaces. For dry installation, the values are:

$$M_t, F_{ax} +8\%$$

$$P_w, P_n -13\%$$

To get these values, the locking device must be completely disassembled and all its component surfaces must be cleaned with solvent. The shaft and hub contact surfaces must also be completely clean and oil-free.

Axial displacement

When tightening the screws there is a hub to shaft axial displacement. The extent of axial displacement depends on the tolerances.

Radial loads

The SIT-LOCK® 6 locking device is suitable for applications subject to high radial loads. For further information, please contact our Technical Department.

Surface finish

Normal surface finish is sufficient. The following values are recommended:

$$R_a \leq 3,2 \mu\text{m} - R_t \leq 16 \mu\text{m}$$

Installation

The locking device is supplied ready to assemble. Clean the shaft contact surfaces thoroughly and apply oil. Mount the shaft, hub and locking device in the desired position.

Screw tightening sequence:

- tighten two diametrically opposed screws until the locking device surfaces make contact with the shaft and hub;
- tighten all screws to 50% of the screw tightening torque value M_s indicated in the table in a 'criss-cross' sequence;
- repeat to 100% of the M_s tightening torque indicated in the table;
- in continuous sequence, check that the tightening torque M_s has been achieved.

Removal

Gradually loosen the clamping screws. Remove the clamping screws and insert them into the special removal threads on the inner ring flange.

Tighten the screws in a 'criss-cross' sequence until the locking device is released.

Reusing the locking device

When reusing the locking device, check all the surfaces are clean and show no obvious signs of deformation or seizing. Clean and oil all surfaces and threads. Check the screws have not been deformed. Oil the screws and assemble the locking device as originally supplied.

SIT-LOCK® 6 internal locking device - self-centering

Dimensions [mm]					Clamping screws DIN 912 12.9			Values with tolerances for shaft h8/hub H8			
d x D	H	H ₀	H ₁	H ₂	Number	Type	M _s [Nm]	M _t [Nm]	F _{ax} [kN]	P _w [N/mm ²]	P _n [N/mm ²]
18 x 47	17	22	28	34	5	M6	14	331	37	318	120
19 x 47	17	22	28	34	5	M6	14	349	37	302	120
20 x 47	17	22	28	34	5	M6	14	367	37	287	120
22 x 47	17	22	28	34	5	M6	14	404	37	261	120
24 x 50	17	22	28	34	5	M6	14	441	37	239	115
25 x 50	17	22	28	34	6	M6	14	551	44	275	140
28 x 55	17	22	28	34	6	M6	14	617	44	246	125
30 x 55	17	22	28	34	6	M6	14	661	44	229	125
32 x 60	17	22	28	34	8	M6	14	940	59	287	150
35 x 60	17	22	28	34	8	M6	14	1.029	59	262	150
38 x 65	17	22	28	34	8	M6	14	1.117	59	241	140
40 x 65	17	22	28	34	8	M6	14	1.176	59	229	140
42 x 75	20	25	33	41	7	M8	35	2.069	99	311	175
45 x 75	20	25	33	41	7	M8	35	2.216	99	290	175
48 x 80	20	25	33	41	7	M8	35	2.364	99	272	160
50 x 80	20	25	33	41	7	M8	35	2.463	99	260	160
55 x 85	20	25	33	41	8	M8	35	3.096	113	271	175
60 x 90	20	25	33	41	8	M8	35	3.377	113	249	165
65 x 95	20	25	33	41	9	M8	35	4.116	127	258	175
70 x 110	24	30	40	50	8	M10	70	6.181	177	279	175
75 x 115	24	30	40	50	8	M10	70	6.623	177	260	170
80 x 120	24	30	40	50	8	M10	70	7.064	177	244	165
85 x 125	24	30	40	50	9	M10	70	8.444	199	258	175
90 x 130	24	30	40	50	9	M10	70	8.941	199	244	170
95 x 135	24	30	40	50	10	M10	70	10.486	221	257	180
100 x 145	26	32	44	56	8	M12	125	13.142	263	268	185
110 x 155	26	32	44	56	8	M12	125	14.456	263	244	175
120 x 165	26	32	44	56	9	M12	125	17.741	296	251	185
130 x 180	34	40	54	64	12	M12	125	25.626	394	237	170
140 x 190	34	40	54	68	9	M14	190	27.214	389	217	160
150 x 200	34	40	54	68	10	M14	190	32.398	432	225	170
160 x 210	34	40	54	68	11	M14	190	38.013	475	232	175
170 x 225	44	50	64	78	12	M14	190	44.061	518	184	140
180 x 235	44	50	64	78	12	M14	190	46.653	518	174	135
190 x 250	44	50	64	78	15	M14	190	61.556	648	206	155
200 x 260	44	50	64	78	15	M14	190	64.796	648	195	150

M _s	Screw tightening torque	Nm
M _t	Transmissible torque	Nm
F _{ax}	Transmissible axial force	kN
P _w	Pressure on shaft	N/mm ²
P _n	Pressure on hub	N/mm ²

IMPORTANT: The screw tightening torque M_s can be reduced by 30% of the value indicated in the table. M_t, F_{ax}, P_w, P_n decrease proportionally. For further information, please contact our Technical Department.

For larger diameters or dimensions different to those in the table, please contact us.

SIT-LOCK® 7 internal locking device - self-centering

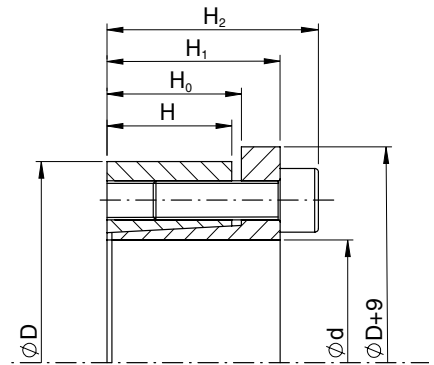
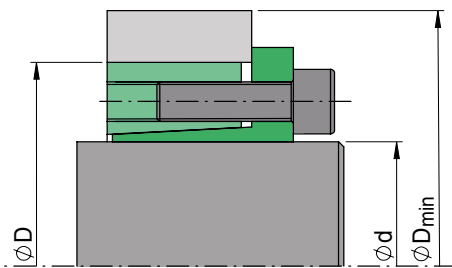

Features

Composed of an inner ring and outer ring both with splits. This type of locking device is particularly suitable for applications that require excellent hub-to-shaft concentricity and perpendicularity. It is also used for locking hubs with limited widths. The table shows performance data for the following tolerances:

shaft d h8 - coupling seat on hub H8

Do not use molybdenum disulphide-based oils or greases that reduce the coefficient of friction μ . The values in the table are calculated with μ 0.12.

Hub to shaft centering

The SIT-LOCK® 7 locking device is self-centering so it does not require a centering base between the shaft and hub. This allows for hubs with reduced widths which saves on materials and leads to reduced costs.

Installation with non-lubricated surfaces (dry)

The SIT-LOCK® 7 locking device is lubricated with oil before delivery to protect it from oxidation during storage. The values shown in the table have been calculated for applications with oiled contact surfaces. For dry installation, the values are:

$M_t, F_{ax} +5\%$

$P_w, P_n -16\%$

To get these values, the locking device must be completely disassembled and all its component surfaces must be cleaned with solvent. The shaft and hub contact surfaces must also be completely clean and oil-free.

Axial displacement

When tightening the screws there is no hub to shaft axial displacement.

Radial loads

SIT-LOCK® 7 is suitable for use with applications subject to high radial loads. For further information, please contact our Technical Department.

Surface finish

Normal surface finish is sufficient. The following values are recommended:

$R_a \leq 3,2 \mu\text{m} - R_t \leq 16 \mu\text{m}$

Installation

The locking device is supplied ready to assemble. Clean the shaft contact surfaces thoroughly and apply oil. Mount the shaft, hub and locking device in the desired position.

Screw tightening sequence:

- tighten two diametrically opposed screws until the locking device surfaces make contact with the shaft and hub;
- tighten all screws to 50% of the screw tightening torque value M_s indicated in the table in a 'criss-cross' sequence;
- repeat to 100% of the M_s tightening torque indicated in the table;
- in continuous sequence, check that the tightening torque M_s has been achieved.

Removal

Gradually loosen the clamping screws. Remove the clamping screws and insert them into the special removal threads on the inner ring flange.

Tighten the screws in a 'criss-cross' sequence until the locking device is released.

Reusing the locking device

When reusing the locking device, check all the surfaces are clean and show no obvious signs of deformation or seizing. Clean and oil all surfaces and threads. Check the screws have not been deformed. Oil the screws and assemble the locking device as originally supplied.

SIT-LOCK® 7 internal locking device - self-centering

Dimensions [mm]					Clamping screws DIN 912 12.9			Values with tolerances for shaft h8/hub H8			
d x D	H	H ₀	H ₁	H ₂	Number	Type	M _s [Nm]	M _t [Nm]	F _{ax} [kN]	P _w [N/mm ²]	P _n [N/mm ²]
18 x 47	17	22	28	34	5	M6	17	252	28	243	95
19 x 47	17	22	28	34	5	M6	17	266	28	230	95
20 x 47	17	22	28	34	5	M6	17	280	28	219	95
22 x 47	17	22	28	34	5	M6	17	308	28	199	95
24 x 50	17	22	28	34	5	M6	17	336	28	182	90
25 x 50	17	22	28	34	6	M6	17	421	34	210	105
28 x 55	17	22	28	34	6	M6	17	471	34	188	95
30 x 55	17	22	28	34	6	M6	17	505	34	175	95
32 x 60	17	22	28	34	8	M6	17	718	45	219	115
35 x 60	17	22	28	34	8	M6	17	785	45	200	115
38 x 65	17	22	28	34	8	M6	17	852	45	184	110
40 x 65	17	22	28	34	8	M6	17	897	45	175	110
42 x 75	20	25	33	41	7	M8	41	1.523	73	229	130
45 x 75	20	25	33	41	7	M8	41	1.632	73	214	130
48 x 80	20	25	33	41	7	M8	41	1.741	73	200	120
50 x 80	20	25	33	41	7	M8	41	1.813	73	192	120
55 x 85	20	25	33	41	8	M8	41	2.280	83	200	130
60 x 90	20	25	33	41	8	M8	41	2.487	83	183	120
65 x 95	20	25	33	41	9	M8	41	3.031	93	190	130
70 x 110	24	30	40	50	8	M10	83	4.607	132	208	130
75 x 115	24	30	40	50	8	M10	83	4.936	132	194	125
80 x 120	24	30	40	50	8	M10	83	5.265	132	182	120
85 x 125	24	30	40	50	9	M10	83	6.293	148	193	130
90 x 130	24	30	40	50	9	M10	83	6.664	148	182	125
95 x 135	24	30	40	50	10	M10	83	7.815	165	191	135
100 x 145	26	32	44	56	8	M12	145	9.582	192	196	135
110 x 155	26	32	44	56	8	M12	145	10.541	192	178	125
120 x 165	26	32	44	56	9	M12	145	12.936	216	183	135
130 x 180	34	40	54	64	12	M12	145	18.686	287	173	125
140 x 190	34	40	54	68	9	M14	230	20.708	296	165	120
150 x 200	34	40	54	68	10	M14	230	24.652	329	171	130
160 x 210	34	40	54	68	11	M14	230	28.925	362	176	135
170 x 225	44	50	64	78	12	M14	230	33.527	394	140	105
180 x 235	44	50	64	78	12	M14	230	35.499	394	132	100
190 x 250	44	50	64	78	15	M14	230	46.839	493	156	120
200 x 260	44	50	64	78	15	M14	230	49.305	493	149	115

M _s	Screw tightening torque	Nm
M _t	Transmissible torque	Nm
F _{ax}	Transmissible axial force	kN
P _w	Pressure on shaft	N/mm ²
P _n	Pressure on hub	N/mm ²

IMPORTANT: The screw tightening torque M_s can be reduced by 40% of the value indicated in the table. M_t, F_{ax}, P_w, P_n decrease proportionally. For further information, please contact our Technical Department.

For larger diameters or dimensions different to those in the table, please contact us.

SIT-LOCK® 8 internal locking device - self-centering

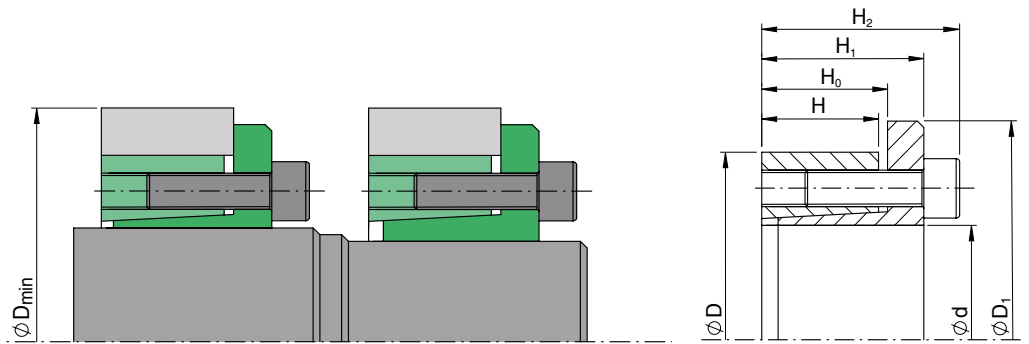

Features

Composed of an inner ring and outer ring both with splits. This type of locking device is particularly suitable for applications that require excellent hub-to-shaft concentricity and perpendicularity. **Allows the same hub, with the same external diameter, to be used on shafts of different diameters.**

Example:

shaft diameter 30 mm: SIT-LOCK® 8 30 x 55
shaft diameter 20 mm: SIT-LOCK® 8 20 x 55

The table shows performance data for the following tolerances:

shaft d h8 - coupling seat on hub H8

Designed for applications that require quick installation, resulting in lower costs. It has the following advantages over SIT-LOCK® 1:

SIT-LOCK® 8 40 x 65

Transmissible torque: **1051 Nm**
Number of screws: **5 M8**
SELF-Centering

SIT-LOCK® 1 40 x 65

Transmissible torque: **1145 Nm**
Number of screws: **14 M6**
NOT SELF-Centering

Notes: using SIT-LOCK® 8 rather than SIT-LOCK® 1 allows for a 65% reduction in installation time and considerably lower application costs.

High torque transmission

With the same shaft size, e.g. 30 mm, it allows for higher torque transmission at a very low cost, for example:

SIT-LOCK® 8 30 x 55 $M_t = 473$ Nm
SIT-LOCK® 8 30 x 65 $M_t = 789$ Nm
SIT-LOCK® 8 30 x 80 $M_t = 1103$ Nm

Do not use molybdenum disulfide-based oils or greases that reduce the coefficient of friction μ . The values in the table are calculated with μ 0.12.

Hub to shaft centering

The SIT-LOCK® 8 locking device is self-centering so it does not require a centering base between the shaft and hub.

Installation with non-lubricated surfaces (dry)

See SIT-LOCK® 7 specifications as they are the same.

Axial displacement

When tightening the screws there is no hub to shaft axial displacement.

Surface finish

Normal surface finish is sufficient. The following values are recommended:

$R_a \leq 3,2 \mu\text{m}$ - $R_t \leq 16 \mu\text{m}$

Installation

The locking device is supplied ready to assemble. Clean the shaft contact surfaces thoroughly and apply oil. Mount the shaft, hub and locking device in the desired position.

Screw tightening sequence:

- tighten two diametrically opposed screws until the locking device surfaces make contact with the shaft and hub;
- tighten all screws to 50% of the screw tightening torque value M_s indicated in the table in a 'criss-cross' sequence;
- repeat to 100% of the M_s tightening torque indicated in the table;
- in continuous sequence, check that the tightening torque M_s has been achieved.

Removal

Gradually loosen the clamping screws. Remove the clamping screws and insert them into the special removal threads on the inner ring flange. Tighten the screws in a 'criss-cross' sequence until the locking device is released.

Reusing the locking device

When reusing the locking device, check all the surfaces are clean and show no obvious signs of deformation or seizing. Clean and oil all surfaces and threads. Check the screws have not been deformed. Oil the screws and assemble the locking device as originally supplied.

SIT-LOCK® 8 internal locking device - self-centering

Dimensions [mm]						Clamping screws DIN 912 12.9			Values with tolerances for shaft h8/hub H8			
d x D	H	H ₀	H ₁	H ₂	D ₁	Number	Type	M _s [Nm]	M _t [Nm]	F _{ax} [kN]	P _w [N/mm ²]	P _n [N/mm ²]
14 x 55	17	22	30	38	62	3	M8	41	221	32	351	90
16 x 55	17	22	30	38	62	3	M8	41	252	32	307	90
18 x 55	17	22	30	38	62	3	M8	41	284	32	273	90
19 x 55	17	22	30	38	62	3	M8	41	299	32	259	90
20 x 55	17	22	30	38	62	3	M8	41	315	32	246	90
22 x 55	17	22	30	38	62	3	M8	41	347	32	224	90
24 x 55	17	22	30	38	62	3	M8	41	378	32	205	90
25 x 55	17	22	30	38	62	3	M8	41	394	32	197	90
28 x 55	17	22	30	38	62	3	M8	41	441	32	176	90
30 x 55	17	22	30	38	62	3	M8	41	473	32	164	90
24 x 65	17	22	30	38	72	5	M8	41	630	53	341	125
25 x 65	17	22	30	38	72	5	M8	41	657	53	328	125
28 x 65	17	22	30	38	72	5	M8	41	735	53	293	125
30 x 65	17	22	30	38	72	5	M8	41	788	53	273	125
32 x 65	17	22	30	38	72	5	M8	41	840	53	256	125
33 x 65	17	22	30	38	72	5	M8	41	866	53	246	125
35 x 65	17	22	30	38	72	5	M8	41	919	53	234	125
38 x 65	17	22	30	38	72	5	M8	41	998	53	216	125
40 x 65	17	22	30	38	72	5	M8	41	1.051	53	205	125
30 x 80	20	25	33	41	87	7	M8	41	1.103	74	325	120
32 x 80	20	25	33	41	87	7	M8	41	1.177	74	305	120
33 x 80	20	25	33	41	87	7	M8	41	1.213	74	296	120
35 x 80	20	25	33	41	87	7	M8	41	1.287	74	279	120
38 x 80	20	25	33	41	87	7	M8	41	1.397	74	257	120
40 x 80	20	25	33	41	87	7	M8	41	1.471	74	244	120
42 x 80	20	25	33	41	87	7	M8	41	1.544	74	232	120
45 x 80	20	25	33	41	87	7	M8	41	1.655	74	217	120
48 x 80	20	25	33	41	87	7	M8	41	1.765	74	203	120
50 x 80	20	25	33	41	87	7	M8	41	1.838	74	195	120

M _s	Screw tightening torque	Nm
M _t	Transmissible torque	Nm
F _{ax}	Transmissible axial force	kN
P _w	Pressure on shaft	N/mm ²
P _n	Pressure on hub	N/mm ²

IMPORTANT: The screw tightening torque M_s can be reduced by 40% of the value indicated in the table. M_t, F_{ax}, P_w, P_n decrease proportionally. For further information, please contact our Technical Department.

For larger diameters or dimensions different to those in the table, please contact us.

SIT-LOCK® 12 internal locking device - self-centering

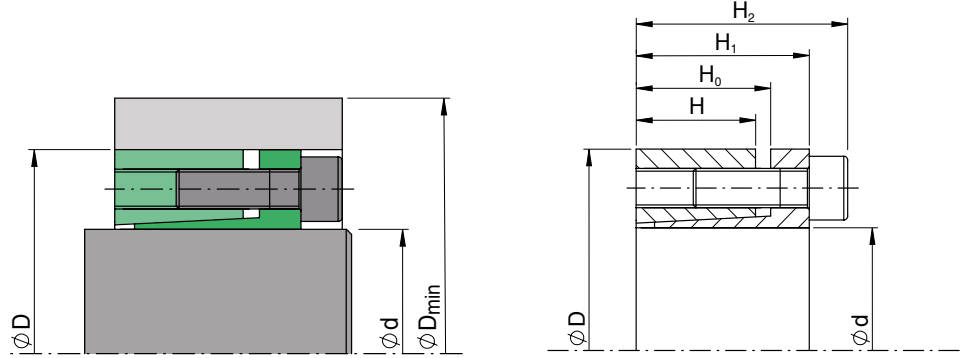

Features

Composed of an inner ring and outer ring both with splits. This type of locking device is particularly suitable for applications that require good hub-to-shaft concentricity and perpendicularity. The table shows performance data for the following tolerances:

shaft d h8 - coupling seat on hub H8

Do not use molybdenum disulphide-based oils or greases that reduce the coefficient of friction μ . The values in the table are calculated with μ 0.12.

Hub to shaft centering

The SIT-LOCK® 12 locking device is self-centering so it does not require a centering base between the shaft and hub. This allows for hubs with reduced widths which saves on materials and leads to reduced costs.

Installation with non-lubricated surfaces (dry)

The SIT-LOCK® 12 locking device is lubricated with oil before delivery to protect it from oxidation during storage. The values shown in the table have been calculated for applications with oiled contact surfaces. For dry installation, the values are:

$$M_t, F_{ax} +8\%$$

$$P_w, P_n -13\%$$

To get these values, the locking device must be completely disassembled and all its component surfaces must be cleaned with solvent. The shaft and hub contact surfaces must also be completely clean and oil-free.

Axial displacement

When tightening the screws there is a hub to shaft axial displacement. The extent of axial displacement depends on the tolerances.

Radial loads

The SIT-LOCK® 12 locking device is suitable for applications subject to high radial loads. For further information, please contact our Technical Department.

Surface finish

Normal surface finish is sufficient. The following values are recommended:

$$R_a \leq 3,2 \mu\text{m} - R_t \leq 16 \mu\text{m}$$

Installation

The locking device is supplied ready to assemble. Clean the shaft contact surfaces thoroughly and apply oil. Mount the shaft, hub and locking device in the desired position.

Screw tightening sequence:

- tighten two diametrically opposed screws until the locking device surfaces make contact with the shaft and hub;
- tighten all screws to 50% of the screw tightening torque value M_s indicated in the table in a 'criss-cross' sequence;
- repeat to 100% of the M_s tightening torque indicated in the table;
- in continuous sequence, check that the tightening torque M_s has been achieved.

Removal

Gradually loosen the clamping screws. Remove the clamping screws and insert them into the special removal threads on the inner ring flange.

Tighten the screws in a 'criss-cross' sequence until the locking device is released.

Reusing the locking device

When the locking device is being reuse, make sure that all the surfaces are clean and show no obvious signs of deformation or seizing. Clean and oil all surfaces and threads. Check the screws have not been deformed. Oil the screws and assemble the locking device as originally supplied.

SIT-LOCK® 12 internal locking device - self-centering

Dimensions [mm]					Clamping screws DIN 912 12.9			Values with tolerances for shaft h8/hub H8			
d x D	H	H ₀	H ₁	H ₂	Number	Type	M _s [Nm]	M _t [Nm]	F _{ax} [kN]	P _w [N/mm ²]	P _n [N/mm ²]
18 x 40	12	15	20	24	6	M4	5	218	24	297	135
19 x 41	12	15	20	24	6	M4	5	230	24	282	130
20 x 42	12	15	20	24	7	M4	5	283	28	312	150
22 x 44	12	15	20	24	7	M4	5	311	28	284	140
24 x 46	12	15	20	24	7	M4	5	339	28	260	135
25 x 47	12	15	20	24	7	M4	5	353	28	250	135
28 x 50	12	15	20	24	9	M4	5	509	36	287	160
30 x 52	12	15	20	24	9	M4	5	545	36	268	155
32 x 54	12	15	20	24	9	M4	5	581	36	251	150
35 x 57	16	19	24	28	10	M4	5	706	40	191	115
36 x 58	16	19	24	28	10	M4	5	727	40	186	115
38 x 60	16	19	24	28	11	M4	5	844	44	194	125
40 x 62	16	19	24	28	11	M4	5	888	44	184	120
42 x 70	19	23	30	36	8	M6	17	1.532	73	243	145
45 x 73	19	23	30	36	8	M6	17	1.641	73	226	140
48 x 76	19	23	30	36	8	M6	17	1.751	73	212	135
50 x 78	19	23	30	36	8	M6	17	1.824	73	204	130
55 x 83	19	23	30	36	8	M6	17	2.006	73	185	125
56 x 84	19	23	30	36	8	M6	17	2.043	73	182	120
60 x 88	19	23	30	36	9	M6	17	2.462	82	191	130
63 x 91	19	23	30	36	9	M6	17	2.585	82	182	125
65 x 93	19	23	30	36	9	M6	17	2.667	82	176	125
70 x 105	23	28	37	45	8	M8	41	4.718	135	222	150
75 x 110	23	28	37	45	8	M8	41	5.055	135	207	140
80 x 115	23	28	37	45	8	M8	41	5.392	135	194	135
85 x 120	23	28	37	45	8	M8	41	5.729	135	183	130
90 x 125	23	28	37	45	10	M8	41	7.582	168	216	155
95 x 130	23	28	37	45	10	M8	41	8.000	168	205	150

M _s	Screw tightening torque	Nm
M _t	Transmissible torque	Nm
F _{ax}	Transmissible axial force	kN
P _w	Pressure on shaft	N/mm ²
P _n	Pressure on hub	N/mm ²

IMPORTANT: The screw tightening torque M_s can be reduced by 40% of the value indicated in the table. M_t, F_{ax}, P_w, P_n decrease proportionally. For further information, please contact our Technical Department.

For larger diameters or dimensions different to those in the table, please contact us.

SIT-LOCK® 15 internal locking device - self-centering

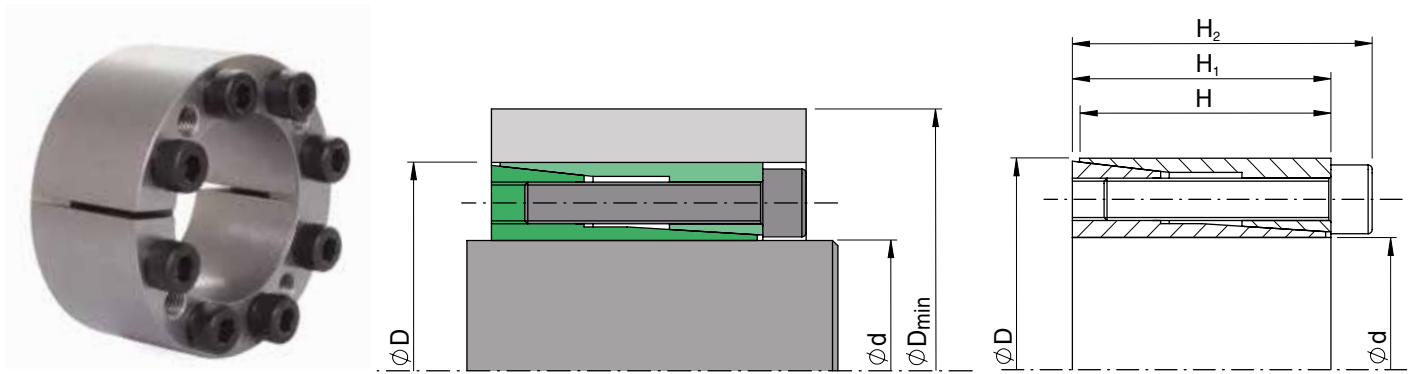

Features

Composed of an inner ring and outer ring both with splits. This type of locking device is particularly suitable for applications that require excellent hub-to-shaft concentricity and perpendicularity. The table shows performance data for the following tolerances:

shaft d h8 - coupling seat on hub H8

Do not use molybdenum disulphide-based oils or greases that reduce the coefficient of friction μ . The values in the table are calculated with μ 0.12.

Hub to shaft centering

The SIT-LOCK® 15 locking device is self-centering so it does not require a centering base between the shaft and hub. This allows for hubs with reduced widths which saves on materials and leads to reduced costs.

Installation with non-lubricated surfaces (dry)

The SIT-LOCK® 15 locking device is lubricated with oil before delivery to protect it from oxidation during storage. The values shown in the table have been calculated for applications with oiled contact surfaces. For dry installation, the values are:

$$M_t, F_{ax} +15\%$$

$$P_w, P_n -13\%$$

To get these values, the locking device must be completely disassembled and all its component surfaces must be cleaned with solvent. The shaft and hub contact surfaces must also be completely clean and oil-free.

Axial displacement

When tightening the screws there is a hub to shaft axial displacement. The extent of axial displacement depends on the tolerances.

Radial loads

The SIT-LOCK® 15 locking device is suitable for applications subject to medium radial loads. For further information, please contact our Technical Department.

Surface finish

Normal surface finish is sufficient. The following values are recommended:

$$R_a \leq 3,2 \mu\text{m} - R_t \leq 16 \mu\text{m}$$

Installation

The locking device is supplied ready to assemble. Clean the shaft contact surfaces thoroughly and apply oil. Mount the shaft, hub and locking device in the desired position.

Screw tightening sequence:

- tighten two diametrically opposed screws until the locking device surfaces make contact with the shaft and hub;
- tighten all screws to 50% of the screw tightening torque value M_s indicated in the table in a 'criss-cross' sequence;
- repeat to 100% of the M_s tightening torque indicated in the table;
- in continuous sequence, check that the tightening torque M_s has been achieved.

Removal

Gradually loosen the clamping screws. Remove the clamping screws and insert them into the special removal threads on the inner ring flange.

Tighten the screws in a 'criss-cross' sequence until the locking device is released.

Reusing the locking device

When reusing the locking device, check all the surfaces are clean and show no obvious signs of deformation or seizing. Clean and oil all surfaces and threads. Check the screws have not been deformed. Oil the screws and assemble the locking device as originally supplied.

SIT-LOCK® 15 internal locking device - self-centering

Dimensions [mm]				Clamping screws DIN 912 12.9			Values with tolerances for shaft h8/hub H8				
d x D	H2	H1	H	Number	Type	M _s [Nm]	M _t [Nm]	F _{ax} [kN]	P _w [N/mm ²]	P _n [N/mm ²]	
5 x 16	13,5	11	10,5	3	M2,5	1,2	8	3	155	50	
6 x 16	13,5	11	10,5	3	M2,5	1,2	9	3	131	50	
6,35 x 16	13,5	11	10,5	3	M2,5	1,2	10	3	124	50	
7 x 17	13,5	11	10,5	3	M2,5	1,2	11	3	112	45	
8 x 18	13,5	11	10,5	3	M2,5	1,2	12	3	98	45	
9 x 20	15	13	12,5	4	M2,5	1,2	19	4	98	45	
9,53 x 20	15	13	12,5	4	M2,5	1,2	20	4	93	45	
10 x 20	15,5	13	12,5	4	M2,5	1,2	21	4	88	45	
11 x 22	15,5	13	12,5	4	M2,5	1,2	23	4	80	40	
12 x 22	15,5	13	12,5	4	M2,5	1,2	25	4	74	40	
12,7 x 26	20	17	16,5	4	M3	2,1	36	6	72	35	
14 x 26	20	17	16,5	4	M3	2,1	40	6	66	35	
15 x 28	20	17	16,5	4	M3	2,1	43	6	62	35	
16 x 32	21	17	16,5	4	M4	4,9	85	11	107	55	
17 x 35	25	21	20,5	4	M4	4,9	90	11	80	40	
18 x 35	25	21	20,5	4	M4	4,9	95	11	77	40	
19 x 35	25	21	20,5	4	M4	4,9	101	11	73	40	
20 x 38	26	21	20,5	4	M5	10	173	17	112	60	
22 x 40	26	21	20,5	4	M5	10	191	17	102	55	
24 x 47	32	26	25	4	M6	17	294	24	105	55	
25 x 47	32	26	25	4	M6	17	306	24	104	55	
28 x 50	32	26	25	6	M6	17	514	37	140	80	
30 x 55	32	26	25	6	M6	17	550	37	130	70	
32 x 55	32	26	25	6	M6	17	587	37	122	70	
35 x 60	37	31	30	8	M6	17	856	49	120	70	
38 x 65	37	31	30	8	M6	17	929	49	110	65	
40 x 65	37	31	28	8	M6	17	978	49	105	65	
42 x 75	44	36	35	6	M8	41	1.424	68	120	70	
45 x 75	44	36	35	6	M8	41	1.525	68	115	70	
48 x 80	44	36	35	8	M8	41	2.169	90	145	85	
50 x 80	44	36	35	8	M8	41	2.260	90	140	85	

M_s Screw tightening torque Nm
 M_t Transmissible torque Nm
 F_{ax} Transmissible axial force kN
 P_w Pressure on shaft N/mm²
 P_n Pressure on hub N/mm²

IMPORTANT: The screw tightening torque M_s can be reduced by 40% of the value indicated in the table. M_t, F_{ax}, P_w, P_n decrease proportionally. For further information, please contact our Technical Department.

For larger diameters or dimensions different to those in the table, please contact us.

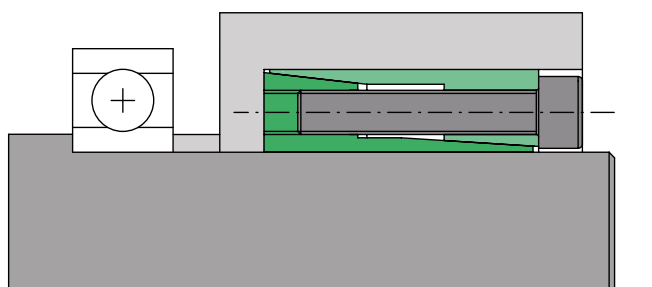

Using SIT-LOCK® 15 to lock a hub while axially locking a bearing. For further information, please contact our Technical Department.

Internal - self-centering

SIT-LOCK® 16 internal locking device - self-centering

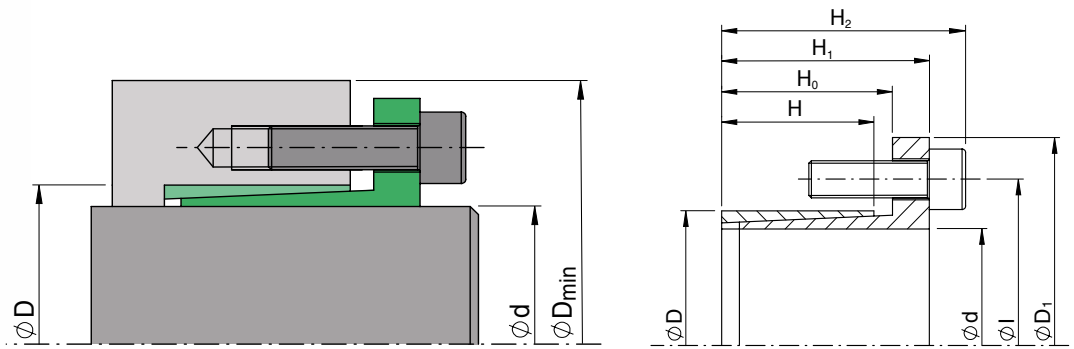

Features

Composed of an inner ring and outer ring both with splits. This type of locking device is particularly suitable for applications that require excellent hub-to-shaft concentricity. It is also used for locking hubs with limited widths and diameters. The table shows performance data for the following tolerances:

shaft d h8 - coupling seat on hub H8

Do not use molybdenum disulphide-based oils or greases that reduce the coefficient of friction μ . The values in the table are calculated with μ 0.12.

Hub to shaft centering

The SIT-LOCK® 16 locking device is self-centering so it does not require a centering base between the shaft and hub. This allows for hubs with reduced widths which saves on materials and leads to reduced costs.

Installation with non-lubricated surfaces (dry)

The SIT-LOCK® 16 locking device is lubricated with oil before delivery to protect it from oxidation during storage. The values shown in the table have been calculated for applications with oiled contact surfaces. For dry installation, the values are:

M_t, F_{ax} +9%

P_w, P_n -13%

To get these values, the locking device must be completely disassembled and all its component surfaces must be cleaned with solvent. The shaft and hub contact surfaces must also be completely clean and oil-free.

Axial displacement

When tightening the screws there is a hub to shaft axial displacement. The axial displacement value depends on the locking device, shaft and hub seat tolerances.

Clamping screws

WARNING: the SIT-LOCK® 16 locking device comes without clamping screws as their length, being related to end-use, can't be set in advance. The values in the table are valid for 12.9 screws. For applications with 8.8 or 10.9 screws, the $M_t - F_{ax} - P_w$ and P_n values will be lower. For further information, please contact our Technical Department.

Surface finish

Normal surface finish is sufficient. The following values are recommended:

$R_a \leq 3,2 \mu\text{m} - R_t \leq 16 \mu\text{m}$

Installation

Clean the shaft contact surfaces thoroughly and apply oil. Mount the shaft, hub and locking device in the desired position.

Screw tightening sequence:

- tighten two diametrically opposed screws until the locking device surfaces make contact with the shaft and hub;
- tighten all screws to 50% of the screw tightening torque value M_s indicated in the table in a 'criss-cross' sequence;
- repeat to 100% of the M_s tightening torque indicated in the table;
- in continuous sequence, check that the tightening torque M_s has been achieved.

Removal

Gradually loosen the clamping screws. Remove the clamping screws and insert them into the special removal threads on the inner ring flange.

Tighten the screws in a 'criss-cross' sequence until the locking device is released.

Reusing the locking device

When reusing the locking device, check all the surfaces are clean and show no obvious signs of deformation or seizing. Clean and oil all surfaces and threads. Check the screws have not been deformed. Oil the screws and assemble the locking device as originally supplied.

SIT-LOCK® 16 internal locking device - self-centering

Dimensions [mm]							Clamping screws DIN 912 12.9 - NOT INCLUDED			Values with tolerances for shaft h8/hub H8			
d x D	H	H ₀	H ₁	H ₂	l	D ₁	Number	Type	M _s [Nm]	M _t [Nm]	F _{ax} [kN]	P _w [N/mm ²]	P _n [N/mm ²]
14 x 25	16	20	26	30	33	42	4	M4	4,9	108	15	183	105
15 x 25	16	20	26	30	33	42	4	M4	4,9	116	15	171	105
16 x 25	16	20	26	30	33	42	4	M4	4,9	124	15	160	105
18 x 25	16	20	26	30	33	42	4	M4	4,9	139	15	143	105
19 x 25	16	20	26	30	33	42	4	M4	4,9	147	15	135	105
20 x 30	16	20	26	31	39	50	4	M5	10,0	253	25	210	140
22 x 30	16	20	26	31	39	50	4	M5	10,0	278	25	191	140
24 x 30	16	20	26	31	39	50	4	M5	10,0	303	25	175	140
25 x 36	16	20	26	31	45	55	4	M5	10,0	316	25	168	115
28 x 36	16	20	26	31	45	55	4	M5	10,0	354	25	150	115
30 x 36	16	20	26	31	45	55	4	M5	10,0	379	25	140	115
32 x 42	16	20	28	33	51	62	4	M5	10,0	405	25	131	100
35 x 42	16	20	28	33	51	62	4	M5	10,0	443	25	120	100
38 x 44	16	20	28	34	54	66	4	M6	17,0	678	36	156	135
40 x 48	16	20	28	34	58	70	4	M6	17,0	714	36	148	135
42 x 48	16	20	28	34	58	70	4	M6	17,0	749	36	141	125
45 x 55	20	25	35	43	67	82	4	M8	41,0	1.484	66	194	160
48 x 55	20	25	35	43	67	82	4	M8	41,0	1.583	66	182	160
50 x 62	20	25	35	43	74	89	4	M8	41,0	1.649	66	175	140
55 x 62	20	25	35	43	74	89	4	M8	41,0	1.813	66	159	140
60 x 72	20	25	35	43	84	99	4	M8	41,0	1.978	66	146	120
65 x 72	20	25	35	43	84	99	4	M8	41,0	2.143	66	135	120

M _s	Screw tightening torque	Nm
M _t	Transmissible torque	Nm
F _{ax}	Transmissible axial force	kN
P _w	Pressure on shaft	N/mm ²
P _n	Pressure on hub	N/mm ²

IMPORTANT: The screw tightening torque M_s can be reduced by 40% of the value indicated in the table. M_t, F_{ax}, P_w, P_n decrease proportionally. For further information, please contact our Technical Department.

For larger diameters or dimensions different to those in the table, please contact us.

SIT-LOCK® 18 internal locking device - self-centering

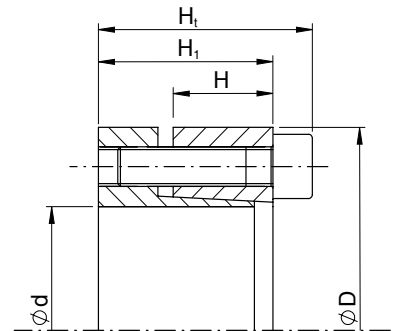
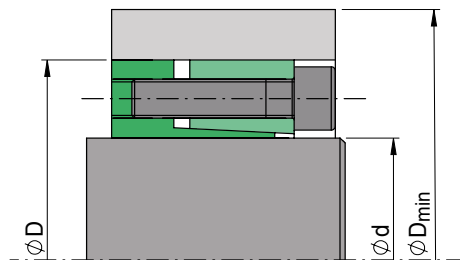

Features

Composed of an inner ring and outer ring both with splits. This type of locking device is particularly suitable for applications that require torque transmission while generating an axial force to axially lock a bearing, washer or any other axially clamped part. The table shows performance data for the following tolerances:

shaft d h8 - coupling seat on hub H8

Do not use molybdenum disulphide-based oils or greases that reduce the coefficient of friction μ . The values in the table are calculated with μ 0.12.

The table shows the M_t , F_{ax} , P_w and P_n values for applications where the hub axially locks a part. For applications that do not require this function, SIT-LOCK® 5A or 5B is recommended.

Hub to shaft centering

The SIT-LOCK® 18 locking device is self-centering so it does not require a centering base between the shaft and hub. This allows for hubs with reduced widths which saves on materials and leads to reduced costs.

Installation with non-lubricated surfaces (dry)

The SIT-LOCK® 18 locking device is lubricated with oil before delivery to protect it from oxidation during storage. The values shown in the table have been calculated for applications with oiled contact surfaces. For dry installation, the values are:

$$M_t, F_{ax} +5\%$$

$$P_w, P_n -16\%$$

To get these values, the locking device must be completely disassembled and all its component surfaces must be cleaned with solvent. The shaft and hub contact surfaces must also be completely clean and oil-free.

Axial displacement

When tightening the screws there is a hub to shaft axial displacement. The extent of axial displacement depends on the tolerances. Axial displacement generates a force on the axially clamped part that is equal to the axial force F_{ax} in the table.

Radial loads

The SIT-LOCK® 18 locking device is suitable for applications subject to high radial loads. For further information, please contact our Technical Department.

Surface finish

Normal surface finish is sufficient. The following values are recommended:

$$R_a \leq 3,2 \mu\text{m} - R_t \leq 16 \mu\text{m}$$

Installation

The locking device is supplied ready to assemble. Clean the shaft contact surfaces thoroughly and apply oil. Mount the shaft, hub and locking device in the desired position. Position the hub axially against the part to be axially clamped.

Screw tightening sequence:

- tighten two diametrically opposed screws until the locking device surfaces make contact with the shaft and hub;
- tighten all screws to 50% of the screw tightening torque value M_s indicated in the table in a 'criss-cross' sequence;
- repeat to 100% of the M_s tightening torque indicated in the table;
- in continuous sequence, check that the tightening torque M_s has been achieved.

Removal

Gradually loosen the clamping screws. Remove the clamping screws and insert them into the special removal threads on the outer ring. Tighten the screws in a 'criss-cross' sequence until the locking device is released.

Reusing the locking device

When reusing the locking device, check all the surfaces are clean and show no obvious signs of deformation or seizing. Clean and oil all surfaces and threads. Check the screws have not been deformed. Oil the screws and assemble the locking device as originally supplied.

SIT-LOCK® 18 internal locking device - self-centering

Dimensions [mm]				Clamping screws DIN 912 12.9			Values with tolerances for shaft h8/hub H8			
d x D	H	H ₁	H _t	Number	Type	M _s [Nm]	M _t [Nm]	F _{ax} [kN]	P _w [N/mm ²]	P _n [N/mm ²]
20 x 47	14	28	34	5	M6	17	280	28	266	95
22 x 47	14	28	34	5	M6	17	308	28	242	95
24 x 50	14	28	34	6	M6	17	404	34	266	90
25 x 50	14	28	34	6	M6	17	421	34	255	105
30 x 55	14	28	34	6	M6	17	505	34	213	95
35 x 60	14	28	34	8	M6	17	785	45	243	115
38 x 65	14	28	34	8	M6	17	852	45	224	110
40 x 65	14	28	34	8	M6	17	897	45	213	110
42 x 75	18	35	43	7	M8	41	1.523	73	255	130
45 x 75	18	35	43	7	M8	41	1.632	73	238	130
50 x 80	18	35	43	7	M8	41	1.813	73	214	120
55 x 85	18	35	43	8	M8	41	2.280	83	222	130
60 x 90	18	35	43	8	M8	41	2.487	83	204	120
65 x 95	18	35	43	9	M8	41	3.031	93	211	130
70 x 110	24	46	56	8	M10	83	4.607	132	208	130

M _s	Screw tightening torque	Nm
M _t	Transmissible torque	Nm
F _{ax}	Transmissible axial force	kN
P _w	Pressure on shaft	N/mm ²
P _n	Pressure on hub	N/mm ²

IMPORTANT: The screw tightening torque M_s can be reduced by 40% of the value indicated in the table. M_t, F_{ax}, P_w, P_n decrease proportionally. For further information, please contact our Technical Department.

For larger diameters or dimensions different to those in the table, please contact us.

SIT-LOCK® 13 internal locking device - self-centering

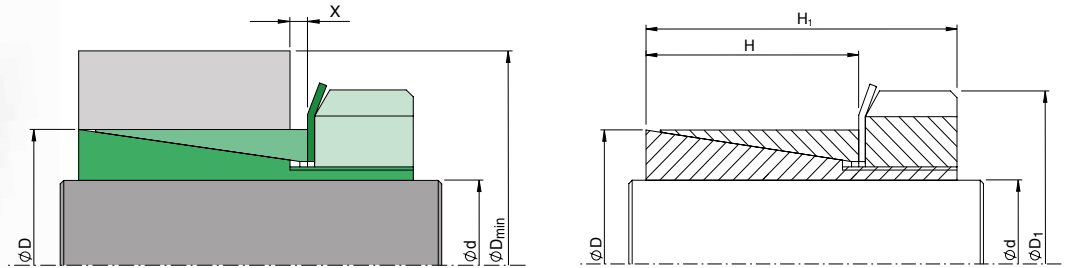

Features

Composed of two tapered rings, an inner ring, a splits outer ring and a ring nut with locking washer. It is suitable for applications that require reduced radial and axial dimensions. Particularly suitable for applications without screw tightening space. The ring nut can actually be tightened from above using a special key of very reduced size. The table shows performance data for the following tolerances:

shaft d h8 - coupling seat on hub H8

Do not use molybdenum disulphide-based oils or greases that reduce the coefficient of friction μ . The values in the table are calculated with μ 0.12.

Hub to shaft centering

The SIT-LOCK® 13 locking device is self-centering so it does not require a centering base between the shaft and hub.

Axial displacement

Application 1: When tightening the ring nut, there is no hub to shaft axial displacement. The values in the table are valid for application 1.

Application 2: When tightening the ring nut, there is hub to shaft axial displacement. M_t , F_{ax} , P_w and P_n values increase by 55% compared to the values shown in the table.

Surface finish

The following values are recommended:

$R_a \leq 3,2 \mu\text{m}$ - $R_t \leq 16 \mu\text{m}$

Considering that using the SIT-LOCK® 2 model requires: tight tolerances, precise surface finishes, and additional accessory costs (flange, screw threads), we recommend using SIT-LOCK® 13.

Installation

Clean the shaft and hub contact surfaces thoroughly. Insert the shaft, the hub and SIT-LOCK® 13 locking device in the desired position.

Nut tightening sequence:

- tighten the ring nut to the tightening torque M_s indicated in the table;
- lock the ring nut using the appropriate locking washer as shown in the figure.

Removal

Unlock the ring nut from the locking washer. Loosen the ring nut until the clamping set is fully removed.

CAUTION: The SIT-LOCK® 13 taper angle is approximately 4° . As the angle is less than the friction angle, removal may not be guaranteed. For applications that require removal, SIT-LOCK® 9 is recommended.

Reusing the locking device

When reusing the locking device, check all the surfaces are clean and show no obvious signs of deformation or seizing. Clean and oil all surfaces and threads. Check the ring nut and washer have not been deformed. Oil the screws and assemble the locking device as originally supplied.

SIT-LOCK® 13 internal locking device - self-centering

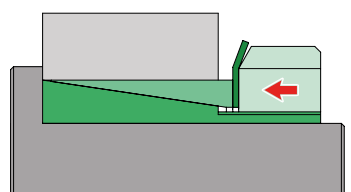

Application 1
 M_t, F_{ax}, P_w, P_n
 values as indicated in the table

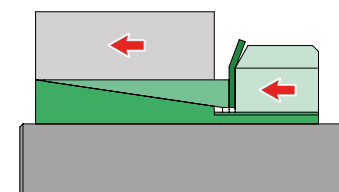

Application 2
 M_t, F_{ax}, P_w, P_n
 55% greater than the values indicated in the table

Dimensions [mm]					Ring nut		Ring nut tightening torque	Values with tolerances for shaft h8/hub H8			
d x D	D ₁	H	H ₁	X	Type	Thread	M _s [Nm]	M _t [Nm]	F _{ax} [kN]	P _w [N/mm ²]	P _n [N/mm ²]
14 x 25	32	23	31	3	KM4	M20x1	95	66	9,2	87	50
15 x 25	32	23	31	3	KM4	M20x1	95	72	9,2	82	50
17 x 25	32	23	31	3	KM4	M20x1	95	81	9,2	74	50
18 x 30	38	24	33	3	KM5	M25x1,5	160	103	11,4	82	50
19 x 30	38	24	33	3	KM5	M25x1,5	160	108	11,4	77	50
20 x 30	38	24	33	3	KM5	M25x1,5	160	115	11,4	73	50
24 x 35	45	29	38	4	KM6	M30x1,5	220	183	15,2	67	45
25 x 35	45	29	38	4	KM6	M30x1,5	220	190	15,2	62	45
28 x 40	52	34	44	4	KM7	M35x1,5	340	257	18,3	57	40
30 x 40	52	34	44	4	KM7	M35x1,5	340	275	18,3	53	40
32 x 45	58	34	45	4	KM8	M40x1,5	480	360	22,5	62	45
35 x 45	58	34	45	4	KM8	M40x1,5	480	393	22,5	57	45
36 x 45	58	34	45	4	KM8	M40x1,5	480	404	22,5	56	45
38 x 50	65	35	46	5	KM9	M45x1,5	680	507	26,7	59	45
40 x 50	65	35	46	5	KM9	M45x1,5	680	534	26,7	57	45
45 x 55	70	35	47	5	KM10	M50x1,5	870	700	31	62	50
48 x 60	75	35	47	5	KM11	M55x2	970	863	36	62	50
50 x 60	75	35	47	5	KM11	M55x2	970	898	36	60	50
55 x 65	80	36	48	5	KM12	M60x2	1.100	1.055	38,5	62	55
60 x 70	85	36	50	5	KM13	M65x2	1.300	1.398	46,6	67	60

M_s Screw tightening torque Nm
 M_t Transmissible torque Nm
 F_{ax} Transmissible axial force kN
 P_w Pressure on shaft N/mm²
 P_n Pressure on hub N/mm²

For larger diameters or dimensions different to those in the table, please contact our Technical Department.

Internal - self-centering

INTERNAL LOCKING DEVICE - NOT SELF-CENTERING

A background image showing several metal flanges of different sizes and orientations, some with internal locking devices. The flanges are arranged in a way that suggests they are components of a larger system.

INTERNAL LOCKING DEVICE NOT SELF-CENTERING

SIT-LOCK® 1 internal locking device - not self-centering

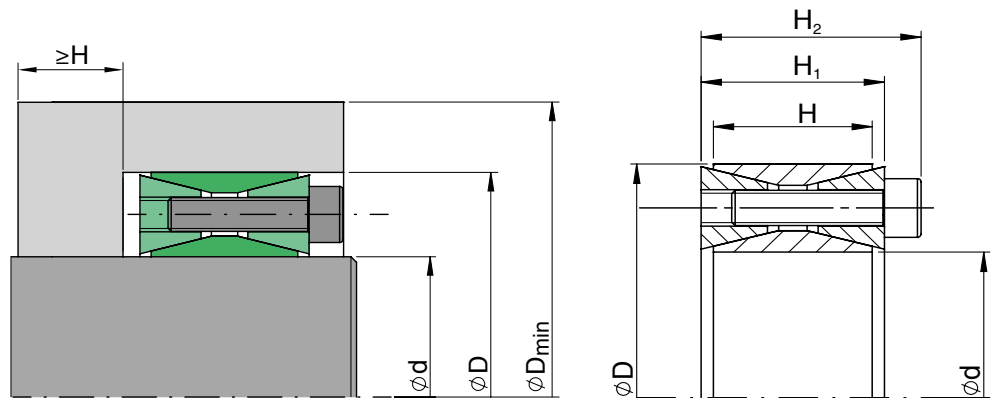

Features

Consisting of two tapered rings with splits, an inner ring and an outer ring, it is particularly suitable for applications that require extensive tolerance. The table shows performance data for the following tolerances:

shaft d h7 - coupling seat on hub H7

shaft d h11 - coupling seat on hub H11

The decrease in performance with h11/H11 tolerances is due to a partial loss of the radial force developed which is required to deform the tapers that are not split.

Do not use molybdenum disulphide-based oils or greases that reduce the coefficient of friction μ . The values in the table are calculated with μ 0.12.

Hub to shaft centering

The SIT-LOCK® 1 locking device is not self-centering so it requires a centering base between the shaft and hub. Where optimum concentricity is required, a centering base with a width $\geq H$ is recommended.

Installation with non-lubricated surfaces (dry)

The SIT-LOCK® 1 locking device is lubricated with oil before delivery to protect it from oxidation during storage. The values shown in the table have been calculated for applications with oiled contact surfaces. For dry installation, the values are:

$$M_t, F_{ax} +15\%$$

$$P_w, P_n -8\%$$

To get these values, the locking device must be completely disassembled and all component surfaces must be cleaned with solvent. The shaft and hub contact surfaces must also be completely dry.

Axial displacement

When tightening the screws there is no hub to shaft axial displacement.

High radial loads

The SIT-LOCK® 1 locking device is not suitable for high radial loads. The taper angle, which is two times greater than the friction angle ϕ , would develop an additional axial force on the screws, which could lead to them breaking. For these types of applications, please contact our Technical Department.

Surface finish

Normal surface finish is sufficient. The following values are recommended:

$$R_a \leq 3,2 \mu\text{m} - R_t \leq 16 \mu\text{m}$$

Applications with more than one SIT-LOCK® 1 device

Where two or more type 1 locking devices are mounted in a row, the total transmissible torque M_t is:

1 device	$M_t = M_t$ indicated in catalogue
2 devices	$M_t = M_t$ indicated in catalogue $\cdot 1,9$
3 devices	$M_t = M_t$ indicated in catalogue $\cdot 2,7$
4 devices	$M_t = M_t$ indicated in catalogue $\cdot 3,6$

Installation

The locking device is supplied ready to assemble. Clean the hub and shaft contact surfaces thoroughly and apply oil. Mount the shaft, hub and locking device in the desired position.

Screw tightening sequence:

- tighten two diametrically opposed screws until the locking device surfaces make contact with the shaft and hub;
- tighten all screws to 50% of the screw tightening torque value M_s indicated in the table in a 'criss-cross' sequence
- repeat to 100% of the M_s tightening torque indicated in the table;
- in continuous sequence, check that the tightening torque M_s has been achieved.

Removal

Gradually loosen the clamping screws. If necessary, lightly tap the screws with a hammer.

SIT-LOCK® 1 internal locking device - not self-centering

Dimensions [mm]				Clamping screws DIN 912 12.9			Values with tolerances for shaft h11/hub H11				Values with tolerances for shaft h7/hub H7			
d x D	H	H ₁	H ₂	Number	Type	M _s [Nm]	M _t [Nm]	F _{ax} [kN]	P _w	P _n	M _t [Nm]	F _{ax} [kN]	P _w	P _n
17 x 47	17	20	26	8	M6	17	280	33	301	110	315	37	342	125
18 x 47	17	20	26	8	M6	17	295	33	284	110	335	37	323	125
19 x 47	17	20	26	8	M6	17	310	33	269	110	355	37	306	125
20 x 47	17	20	26	8	M6	17	325	33	255	110	375	37	291	125
22 x 47	17	20	26	8	M6	17	360	33	232	110	410	37	265	125
24 x 50	17	20	26	8	M6	17	395	33	213	100	450	37	243	115
25 x 50	17	20	26	8	M6	17	410	33	204	100	465	37	233	115
28 x 55	17	20	26	10	M6	17	575	41	228	115	655	47	260	130
30 x 55	17	20	26	10	M6	17	615	41	213	115	700	47	243	130
32 x 60	17	20	26	12	M6	17	785	49	239	130	895	56	273	145
35 x 60	17	20	26	12	M6	17	860	49	219	130	980	56	250	145
38 x 65	17	20	26	14	M6	17	1.090	57	235	140	1.240	65	268	155
40 x 65	17	20	26	14	M6	17	1.145	57	224	140	1.305	65	255	155
42 x 75	20	24	32	12	M8	41	1.860	89	280	155	2.170	103	327	185
45 x 75	20	24	32	12	M8	41	1.995	89	261	155	2.325	103	305	185
48 x 80	20	24	32	12	M8	41	2.125	89	245	145	2.480	103	286	170
50 x 80	20	24	32	12	M8	41	2.215	89	235	145	2.585	103	274	170
55 x 85	20	24	32	14	M8	41	2.845	103	249	160	3.320	121	291	190
60 x 90	20	24	32	14	M8	41	3.100	103	229	150	3.620	121	267	180
65 x 95	20	24	32	16	M8	41	3.840	118	241	165	4.480	138	281	195
70 x 110	24	28	38	14	M10	83	5.610	160	253	160	6.705	192	302	195
75 x 115	24	28	38	14	M10	83	6.010	160	236	155	7.185	192	282	185
80 x 120	24	28	38	14	M10	83	6.410	160	221	150	7.665	192	265	175
85 x 125	24	28	38	16	M10	83	7.785	183	238	160	9.305	219	285	195
90 x 130	24	28	38	16	M10	83	8.245	183	225	155	9.850	219	269	185
95 x 135	24	28	38	18	M10	83	9.790	206	240	170	11.700	246	287	200
100 x 145	26	33	45	14	M12	145	11.315	226	231	160	13.945	279	285	195
110 x 155	26	33	45	14	M12	145	12.445	226	210	150	15.340	279	259	185
120 x 165	26	33	45	16	M12	145	15.515	259	220	160	19.125	319	271	195
130 x 180	34	38	50	20	M12	145	21.010	323	194	140	25.900	398	239	175
140 x 190	34	38	50	22	M12	145	24.890	356	198	145	30.680	438	244	180
150 x 200	34	38	50	24	M12	145	29.090	388	202	150	35.860	478	249	185
160 x 210	34	38	50	26	M12	145	33.620	420	205	155	41.440	518	253	190
170 x 225	38	44	58	22	M14	230	40.425	476	195	150	51.120	601	247	185
180 x 235	38	44	58	24	M14	230	46.695	519	201	155	59.045	656	254	195
190 x 250	46	52	66	28	M14	230	57.505	605	184	140	72.715	765	232	175
200 x 260	46	52	66	30	M14	230	64.855	649	187	145	82.010	820	236	180
220 x 285	50	56	72	26	M16	355	84.600	769	185	145	108.660	988	238	185
240 x 305	50	56	72	30	M16	355	106.490	887	196	155	136.775	1.140	252	200
260 x 325	50	56	72	34	M16	355	130.745	1.006	205	165	167.930	1.292	264	210
280 x 355	60	66	84	32	M18	485	157.365	1.124	177	140	204.805	1.463	231	180
300 x 375	60	66	84	36	M18	485	189.685	1.265	186	150	246.865	1.646	243	195
320 x 405	72	78	98	36	M20	690	259.690	1.623	187	150	341.605	2.135	246	194
340 x 425	72	78	98	36	M20	690	275.920	1.623	176	140	362.955	2.135	231	185
360 x 455	84	90	112	36	M22	930	360.740	2.004	176	140	478.385	2.658	233	185
380 x 475	84	90	112	36	M22	930	380.780	2.004	167	135	504.960	2.658	221	175
400 x 495	84	90	112	36	M22	930	400.820	2.004	158	130	531.535	2.658	210	170
420 x 515	84	90	112	40	M22	930	467.625	2.227	167	135	620.125	2.953	222	180
440 x 545	96	102	126	40	M24	1200	557.315	2.533	159	130	750.230	3.410	214	175
460 x 565	96	102	126	40	M24	1200	582.645	2.533	152	125	784.330	3.410	205	165
480 x 585	96	102	126	42	M24	1200	638.380	2.660	153	125	859.355	3.581	206	170
500 x 605	96	102	126	44	M24	1200	696.645	2.787	154	125	937.790	3.751	207	170
520 x 630	96	102	126	45	M24	1200	740.975	2.850	151	125	997.465	3.836	204	170
540 x 650	96	102	126	45	M24	1200	769.475	2.850	146	120	1.035.830	3.836	196	165
560 x 670	96	102	126	48	M24	1200	851.170	3.040	150	125	1.145.805	4.092	202	170
580 x 690	96	102	126	50	M24	1200	918.300	3.167	151	125	1.236.175	4.263	203	170
600 x 710	96	102	126	50	M24	1200	949.965	3.167	146	120	1.278.800	4.263	196	165

IMPORTANT: The screw tightening torque M_s can be reduced by 40% of the value indicated in the table. M_t, F_{ax}, P_w, P_n decrease proportionally. For further information, please contact our Technical Department.

Internal - not self-centering

SIT-LOCK® 9 internal locking device - not self-centering

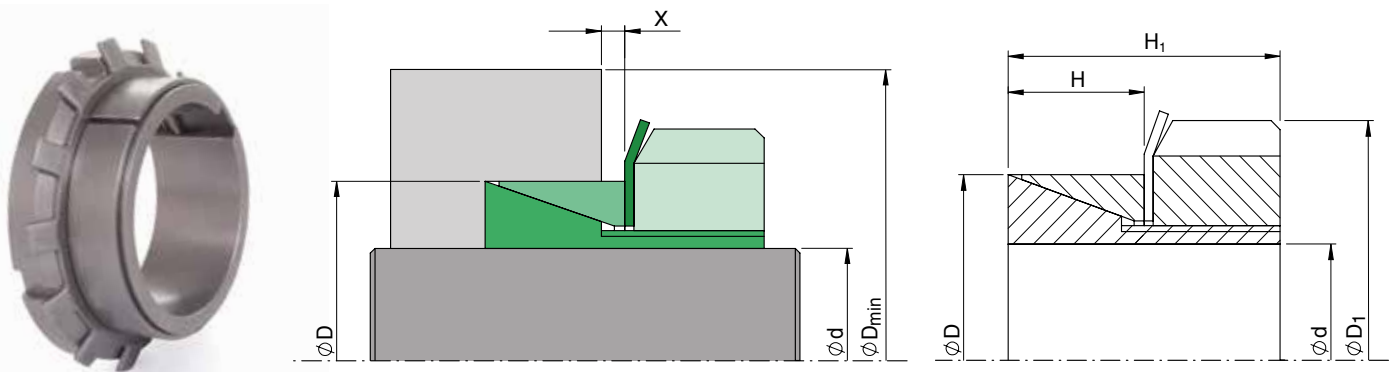

Features

Composed of two tapered rings, an inner ring, a split outer ring and a ring nut with locking washer. It is suitable for applications that require reduced radial and axial dimensions. Particularly suitable for applications without screw tightening space. The ring nut can actually be tightened from above using a special key of very reduced size. The table shows performance data for the following tolerances:

shaft d h8 - coupling seat on hub H8

Do not use molybdenum disulphide-based oils or greases that reduce the coefficient of friction μ . The values in the table are calculated with μ 0.12.

Hub to shaft centering

The SIT-LOCK® 9 locking device is not self-centering so it requires a centering base between the shaft and hub. A centering width of $\geq 2 \cdot H_1$ is recommended.

Axial displacement

Application 1: When tightening the ring nut, there is no hub to shaft axial displacement. The values in the table are valid for application 1.

Application 2: When tightening the ring nut, there is hub to shaft axial displacement. The M_t , F_{ax} , P_w and P_n values increase by 28% compared to the values shown in the table.

Surface finish

The following values are recommended:

$$R_a \leq 3,2 \mu\text{m} - R_t \leq 16 \mu\text{m}$$

Considering that using the SIT-LOCK® 2 model requires tight tolerances, precise surface finishes, and additional accessory costs (flange, screw threads), we recommend using SIT-LOCK® 9.

Installation

Clean the shaft and hub contact surfaces thoroughly. Insert the shaft, the hub and SIT-LOCK® 9 locking device in the desired position.

Nut tightening sequence:

- tighten the ring nut to the tightening torque M_s indicated in the table;
- lock the ring nut using the appropriate locking washer as shown in the figure.

Removal

- unlock the ring nut from the locking washer. Loosen the ring nut until the locking device is fully removed;
- removal may be difficult in some applications because there are no disassembly threads as a ring nut is used for locking.

Reusing the locking device

When reusing the locking device, check all the surfaces are clean and show no obvious signs of deformation or seizing. Clean and oil all surfaces and threads. Check the ring nut and washer have not been deformed. Oil the screws and assemble the locking device as originally supplied.

SIT-LOCK® 9 internal locking device - not self-centering

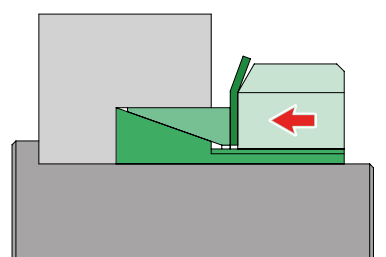

Application 1
 M_t, F_{ax}, P_w, P_n
 values as indicated in the table

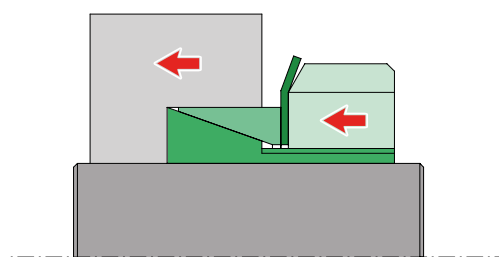

Application 2
 M_t, F_{ax}, P_w, P_n
 greater than +28% of values in the table

Dimensions [mm]					Ring nut		Ring nut tightening torque	Values with tolerances for shaft h8/hub H8			
d x D	D ₁	H	H ₁	X	Type	Thread	M _s [Nm]	M _t [Nm]	F _{ax} [kN]	P _w [N/mm ²]	P _n [N/mm ²]
14 x 25	32	9	17	2,5	KM4	M20x1	95	45	6	238	130
15 x 25	32	9	17	2,5	KM4	M20x1	95	56	6	220	130
16 x 25	32	9	17	2,5	KM4	M20x1	95	51	6	207	130
17 x 26	38	9	18	2,5	KM5	M25x1,5	160	65	7,1	234	135
18 x 26	38	9	18	2,5	KM5	M25x1,5	160	69	7,1	221	155
18 x 30	38	9	17,5	2,5	KM5	M25x1,5	160	69	7,1	221	135
19 x 30	38	9	18	2,5	KM5	M25x1,5	160	73	8,3	210	135
20 x 30	38	9	18	2,5	KM5	M25x1,5	160	78	8,3	198	130
22 x 32	45	9	18	2,5	KM6	M30x1,5	220	114	9,5	240	165
24 x 35	45	9	18	2,5	KM6	M30x1,5	220	125	10,7	220	150
25 x 35	45	9	18	2,5	KM6	M30x1,5	220	130	10,7	211	150
28 x 36	52	10	18	3	KM7	M35x1,5	340	178	11,9	209	160
28 x 40	52	9	18	3	KM7	M35x1,5	340	178	11,9	209	145
30 x 40	52	11	20	3	KM7	M35x1,5	340	190	13,1	195	145
32 x 42	58	11	22	3	KM8	M40x1,5	480	250	15,5	200	150
35 x 45	58	11	22	3	KM8	M40x1,5	480	250	15,5	200	145
36 x 45	58	11	22	3	KM8	M40x1,5	480	285	15,5	177	145
38 x 48	65	14	25	4	KM9	M45x1,5	680	345	16,7	150	120
40 x 50	65	14	25	4	KM9	M45x1,5	680	369	17,8	143	115
40 x 52	65	14	25	4	KM9	M45x1,5	680	369	17,8	143	110
42 x 55	70	14	26	4	KM10	M50x1,5	870	440	20,2	156	120
45 x 55	70	14	26	4	KM10	M50x1,5	870	476	21,4	145	120
48 x 62	75	14	26	4	KM11	M55x2	970	595	25	160	125
50 x 60	75	14	26	4	KM11	M55x2	970	618	25	155	130
50 x 62	75	14	26	4	KM11	M55x2	970	618	25	155	125
55 x 65	80	15	27	4	KM12	M60x2	1.100	725	26,1	122	105
55 x 68	80	15	27	4	KM12	M60x2	1.100	725	26,1	122	100
56 x 68	80	15	27	4	KM12	M60x2	1.100	737	26,1	120	95
60 x 70	85	15	29	4	KM13	M65x2	1.300	952	32,1	134	110
60 x 73	85	15	29	4	KM13	M65x2	1.300	952	32,1	134	110
63 x 79	92	17	31	4	KM14	M70x2	1.600	1.166	36,9	127	100
65 x 79	92	17	31	4	KM14	M70x2	1.600	1.200	36,9	124	100
70 x 84	98	17	31	4	KM15	M75x2	2.000	1.475	41,6	131	110

M_s Screw tightening torque Nm
 M_t Transmissible torque Nm
 F_{ax} Transmissible axial force kN
 P_w Pressure on shaft N/mm²
 P_n Pressure on hub N/mm²

For dimensions not included in the table, please contact our Technical Department.

Internal - not self-centring

SIT-LOCK® 2 internal locking device - not self-centering

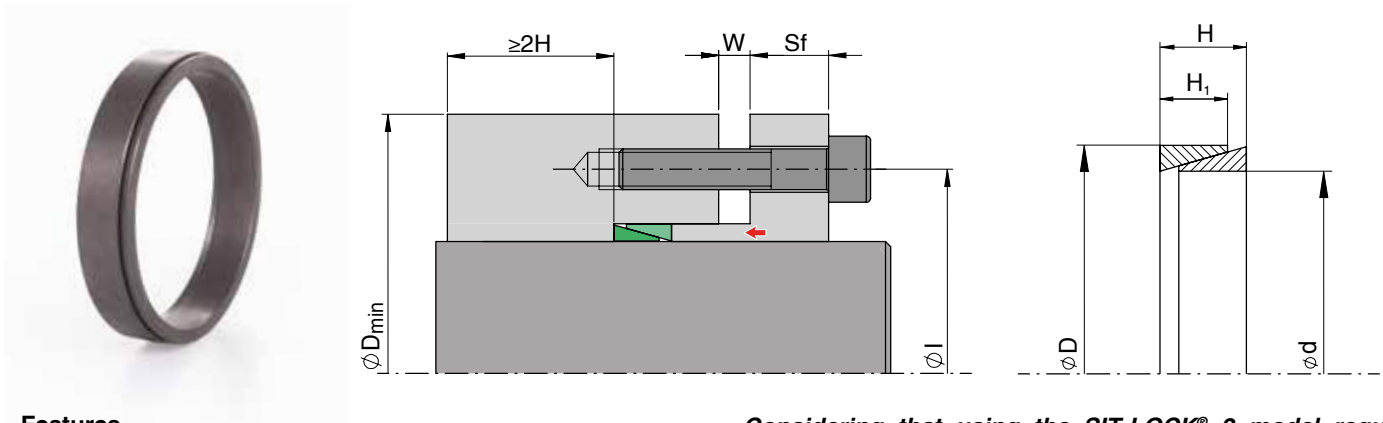

Features

Composed of two tapered rings, it is suitable for applications that require smaller dimensions. The table shows performance data for the following tolerances:

shaft d h6 - hub seat H7 for $d \leq 40$ mm

shaft d h8 - hub seat H8 for $d \geq 42$ mm

Do not use molybdenum disulphide-based oils or greases that reduce the coefficient of friction μ . The values in the table are calculated with μ 0.12.

Hub to shaft centering

The SIT-LOCK® 2 locking device is not self-centering so it requires a centering base between the shaft and hub. A centering width of $\geq 2 \cdot H$ is recommended.

Axial displacement

Application 1: When tightening the screws, there is no hub to shaft axial displacement. The values in the table are valid for application 1.

Application 2: When tightening the screws, there is hub to shaft axial displacement. The M_t , F_{ax} , P_w and P_n values increase by 28% compared to the values shown in the table.

Surface finish

The following values are recommended:

$$R_t \leq 6 \mu\text{m} - R_a \leq 1 \mu\text{m}$$

Applications with more than one SIT-LOCK® 2 device

Where two or more SIT-LOCK® 2 locking devices are mounted in a row, the total transmissible torque M_t is:

- 1 device $M_t = M_t$ indicated in catalogue
- 2 devices $M_t = M_t$ indicated in catalogue $\cdot 1,55$
- 3 devices $M_t = M_t$ indicated in catalogue $\cdot 1,86$
- 4 devices $M_t = M_t$ indicated in catalogue $\cdot 2,03$

SIT-LOCK® 2 split version

The SIT-LOCK® 2 is available in a split version on request. In this case, consider the table force P_0 equal to 0.

Considering that using the SIT-LOCK® 2 model requires tight tolerances, precise surface finishes, and additional accessory costs (flange, screw threads), we recommend using SIT-LOCK® 3. See dedicated page.

Calculating transmissible torque M_t

$$M_t = \frac{P_{tot} - P_0}{\text{tg } \alpha + 2\mu} \cdot \mu \cdot \frac{d}{2}$$

where:

- P_{tot} = total force given by the screws $P_v \cdot N^\circ$ of screws
- P_0 = force required to deform rings without splits
- $\text{tg } \alpha$ = tangent to the angle of the rings. $\text{tg } \alpha = 0.3$
- μ = coefficient of friction. Value found to be 0.12
- d = shaft diameter

Table for determining the P_v force depending on the M_s value						
dg	Axial force P_v in N			Tightening torque M_s in Nm		
	8.8	10.9	12.9	8.8	10.9	12.9
M2,5	1.600	2.140	2.565	0,76	1,0	1,2
M3	2.210	3.110	3.730	1,3	1,9	2,2
M4	3.900	5.450	6.550	2,9	4,1	4,9
M5	6.350	8.950	10.700	6,0	8,5	10
M6	9.000	12.600	15.100	10	14	17
M8	16.500	23.200	27.900	25	35	41
M10	26.200	36.900	44.300	49	69	83
M12	38.300	54.000	64.500	86	120	145
M14	52.500	74.000	88.500	135	190	230
M16	73.000	102.000	123.000	210	295	355
M18	88.000	124.000	148.000	290	405	485
M20	114.000	160.000	192.000	410	580	690
M22	141.000	199.000	239.000	550	780	930
M24	164.000	230.000	276.000	710	1.000	1.200

Installation

- tighten all screws to 50% of the screw tightening torque value M_s indicated in the table in a 'criss-cross' sequence;
- repeat to 100% of the M_s tightening torque indicated in the table;
- in continuous sequence, check that the tightening torque M_s has been achieved.

Removal

Gradually loosen the clamping screws until the rings are fully removed.

SIT-LOCK® 2 internal locking device - not self-centering

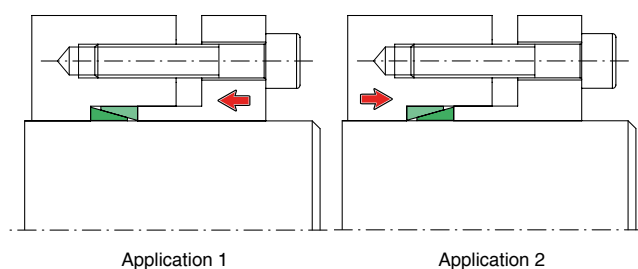

Calculating the screw spacing l

For applications with hub fixed screws:

$$l = D + 12 + dg$$

For applications with shaft fixed screws:

$$l = d - 12 - dg$$

dg = clamping screw diameter

Calculating flange thickness Sf

For applications with 8.8 screws

$$Sf \geq dg \cdot 1,3$$

For applications with 10.9/12.9 screws

$$Sf \geq dg \cdot 1,8$$

Dimensions [mm]			Pre-load force P ₀ [kN]	Total force P _{tot} [kN]	Performance		Distance free of clamping screws (W) [mm]				Pressures [N/mm ²]	
d x D	H	H ₁			M _t [Nm]	F _{ax} [kN]	1	2	3	4	P _w	P _n
6 x 9	4,5	3,7	-	4	3	0,9	2,5	2,5	3,0	4,0	106	71
7 x 10	4,5	3,7	-	5	4	1,1	2,5	2,5	3,0	4,0	114	80
8 x 11	4,5	3,7	-	6	5	1,3	2,5	2,5	3,0	4,0	119	87
9 x 12	4,5	3,7	8	15	7	1,6	2,5	2,5	3,0	4,0	130	98
10 x 13	4,5	3,7	7	16	10	2,0	2,5	2,5	3,0	4,0	143	110
12 x 15	4,5	3,7	7	16	12	2,0	2,5	2,5	3,0	4,0	119	96
13 x 16	4,5	3,7	7	16	14	2,1	2,5	2,5	3,0	4,0	116	95
14 x 18	6,3	5,3	11	26	23	3,3	3,5	3,5	4,5	5,5	119	93
15 x 19	6,3	5,3	11	27	27	3,6	3,5	3,5	4,5	5,5	120	95
16 x 20	6,3	5,3	10	27	30	3,8	3,5	3,5	4,5	5,5	118	95
17 x 21	6,3	5,3	10	27	33	3,9	3,5	3,5	4,5	5,5	114	92
18 x 22	6,3	5,3	9	33	48	5,3	3,5	3,5	4,5	5,5	147	121
19 x 24	6,3	5,3	13	33	43	4,6	3,5	3,5	4,5	5,5	120	95
20 x 25	6,3	5,3	12	33	47	4,7	3,5	3,5	4,5	5,5	117	93
22 x 26	6,3	5,3	9	34	61	5,6	3,5	3,5	4,5	5,5	126	107
24 x 28	6,3	5,3	8	34	68	5,7	3,5	3,5	4,5	5,5	119	102
25 x 30	6,3	5,3	10	37	75	6,0	3,5	3,5	4,5	5,5	120	100
28 x 32	6,3	5,3	8	40	101	7,2	3,5	3,5	4,5	5,5	129	113
30 x 35	6,3	5,3	9	40	105	7,0	3,5	3,5	4,5	5,5	116	100
32 x 36	6,3	5,3	8	44	128	8,0	3,5	3,5	4,5	5,5	125	112
35 x 40	7,0	6,0	10	54	171	9,8	3,5	3,5	4,5	5,5	124	108
36 x 42	7,0	6,0	12	57	181	10,1	3,5	3,5	4,5	5,5	124	106
38 x 44	7,0	6,0	11	60	207	10,9	3,5	3,5	4,5	5,5	127	109
40 x 45	8,0	6,6	14	70	249	12,5	3,5	4,5	5,5	6,5	125	111
42 x 48	8,0	6,6	16	75	278	13,2	3,5	4,5	5,5	6,5	127	111
45 x 52	10,0	8,6	28	110	409	18,2	3,5	4,5	5,5	6,5	124	108
48 x 55	10,0	8,6	25	110	455	19,0	3,5	4,5	5,5	6,5	122	106
50 x 57	10,0	8,6	24	110	480	19,2	3,5	4,5	5,5	6,5	118	104
55 x 62	10,0	8,6	22	120	601	21,8	3,5	4,5	5,5	6,5	123	109
56 x 64	12,0	10,4	30	150	750	26,8	3,5	4,5	5,5	7,0	122	107
60 x 68	12,0	10,4	28	160	883	29,4	3,5	4,5	5,5	7,0	125	110
63 x 71	12,0	10,4	27	170	1.005	31,9	3,5	4,5	5,5	7,0	129	115
65 x 73	12,0	10,4	26	170	1.044	32,1	3,5	4,5	5,5	7,0	126	112
70 x 79	14,0	12,2	31	210	1.392	39,8	3,5	5,0	6,5	7,5	124	109
71 x 80	14,0	12,2	31	220	1.491	42,0	3,5	5,0	6,5	7,5	129	114
75 x 84	14,0	12,2	35	230	1.628	43,4	3,5	5,0	6,5	7,5	126	112
80 x 91	17,0	15,0	48	300	2.240	56,0	4,0	6,0	6,5	8,0	124	109
85 x 96	17,0	15,0	46	320	2.593	61,0	4,0	6,0	6,5	8,0	127	112
90 x 101	17,0	15,0	44	330	2.864	63,6	4,0	6,0	6,5	8,0	125	111
95 x 106	17,0	15,0	41	340	3.153	66,4	4,0	6,0	6,5	8,0	124	111
100 x 114	21,0	18,7	61	460	4.433	88,7	5,0	6,0	7,0	9,0	126	110
110 x 124	21,0	18,7	66	475	4.999	90,9	5,0	6,0	7,0	9,0	117	104
120 x 134	21,0	18,7	60	475	5.529	92,2	5,0	6,0	7,0	9,0	109	98
130 x 148	28,0	25,3	96	700	8.720	134	5,0	7,0	9,0	11,0	108	95
140 x 158	28,0	25,3	89	740	10.127	145	6,0	7,0	9,0	11,0	108	96
150 x 168	28,0	25,3	85	790	11.750	157	6,0	7,0	8,0	11,0	110	98
160 x 178	28,0	25,3	79	950	15.492	194	6,0	7,0	9,0	11,0	127	114
170 x 191	33,0	30,0	117	1.180	20.071	236	7,0	9,0	10,0	12,0	123	109
180 x 201	33,0	30,0	111	1.200	21.774	242	7,0	9,0	10,0	12,0	119	106
190 x 211	33,0	30,0	105	1.300	25.228	266	7,0	9,0	10,0	12,0	124	111
200 x 224	38,0	34,8	134	1.600	32.573	326	7,0	8,0	11,0	13,0	124	111
220 x 244	38,0	34,8	142	1.700	37.185	345	7,0	9,0	11,0	13,0	124	111
240 x 267	43,0	39,5	157	2.250	51.000	425	7,0	10,0	12,0	14,0	120	108

For dimensions not included in the table, please contact our Technical Department.
Available with slit rings on request. Using SIT-LOCK® 2 with slit rings allows increased transmissible torque.

SIT-LOCK® 10 - rigid joint

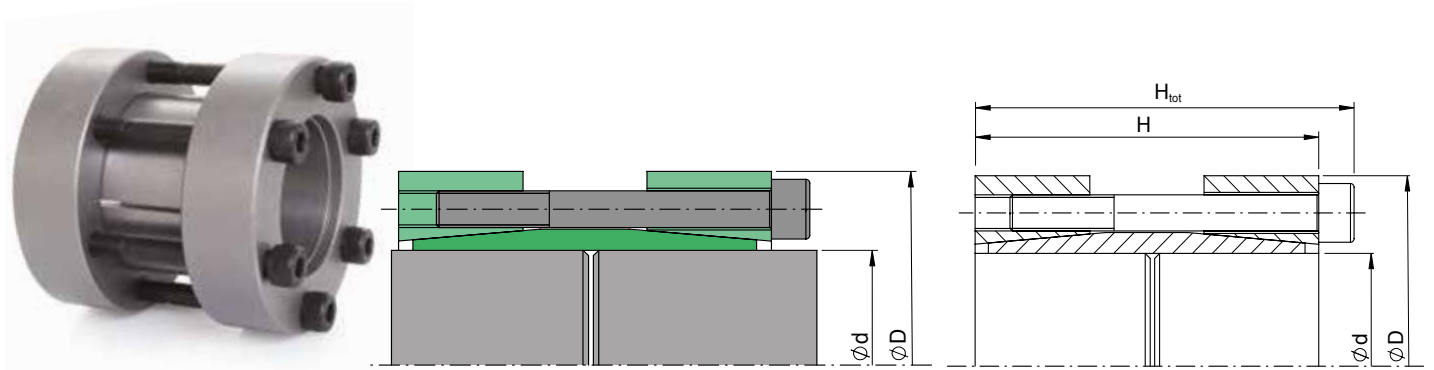

Features

Composed of two tapered rings and a split inner ring. It is particularly suitable for clamping two shafts where medium-high torque transmission is required. The table shows performance data for the following tolerances:

shaft $d\ h9$

Do not use molybdenum disulphide-based oils or greases that reduce the coefficient of friction μ . The values in the table are calculated with $\mu\ 0.12$.

Installation with non-lubricated surfaces (dry)

The SIT-LOCK® 10 locking device is lubricated with oil before delivery to protect it from oxidation during storage. The values shown in the table have been calculated for applications with oiled contact surfaces. For dry installation, the values are:

$M_t, F_{ax} +25\%$

To get these value, the shaft and rigid joint inner ring contact surfaces must be cleaned with solvent. The shaft contact surfaces must also be completely dry.

Surface finish

Normal surface finish is sufficient. The following values are recommended:

$R_a \leq 3,2\ \mu m - R_t \leq 16\ \mu m$

Axial displacement

When tightening the screws there is a hub to shaft axial displacement. The axial displacement value depends on the locking device, shaft and hub seat tolerances.

Installation

The coupling is supplied ready to assemble. Clean the shaft contact surfaces thoroughly and apply oil. Place the rigid joint between the two shafts to be connected, then:

- tighten two opposite screws until the coupling's inner ring surface makes contact with the shafts being joined;

- tighten all screws to 50% of the screw tightening torque value M_s indicated in the table in a 'criss-cross' sequence;
- repeat to 100% of the M_s tightening torque indicated in the table;
- in continuous sequence, check that the tightening torque M_s has been achieved. Installation is complete when all screws are tightened to the M_s tightening torque indicated in the table.

Removal

- gradually loosen the clamping screws. This is usually enough to unlock the two tapered outer rings;
- if necessary, lightly tap the tapered rings with a hammer to facilitate removal.

Reusing the rigid joint

For applications of considerable quantities, we can make a device with an inner ring that can couple two shafts of different diameters. See figure.

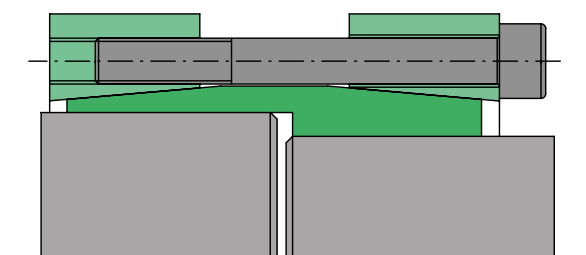

For quantities that do not justify mass production, we recommend making a split bushing to achieve the purpose of a serial joint. See figure.

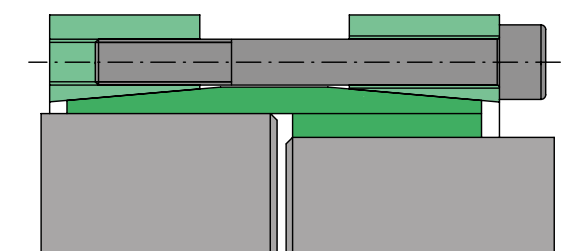

Recommended split bushing tolerances:
inner diameter E7 - outer diameter e7

SIT-LOCK® 10 - rigid joint

Dimensions [mm]			Clamping screws DIN 912 12.9			Values with tolerances for shaft h8/hub H8	
d x D	H _t	H	Number	Type	M _s [Nm]	M _t [Nm]	F _{ax} [kN]
15 x 45	56	50	4	M6	17	173	23
17 x 50	56	50	4	M6	17	196	23
18 x 50	56	50	4	M6	17	207	23
19 x 50	56	50	4	M6	17	219	23
20 x 50	56	50	4	M6	17	231	23
22 x 55	66	60	6	M6	17	380	35
24 x 55	66	60	6	M6	17	415	35
25 x 55	66	60	6	M6	17	432	35
28 x 60	66	60	6	M6	17	484	35
30 x 60	66	60	6	M6	17	519	35
32 x 63	66	60	6	M6	17	553	35
35 x 75	83	75	4	M8	41	764	44
38 x 75	83	75	4	M8	41	829	44
40 x 75	83	75	4	M8	41	873	44
42 x 78	83	75	4	M8	41	916	44
45 x 85	93	85	6	M8	41	1.473	65
48 x 90	93	85	6	M8	41	1.571	65
50 x 90	93	85	6	M8	41	1.636	65
55 x 94	93	85	8	M8	41	2.400	87
60 x 100	93	85	8	M8	41	2.618	87
65 x 105	93	85	8	M8	41	2.836	87
70 x 115	110	100	6	M10	83	3.551	101
75 x 120	110	100	6	M10	83	3.805	101
80 x 125	110	100	8	M10	83	5.411	135

M_s Screw tightening torque Nm
M_t Transmissible torque Nm
F_{ax} Transmissible axial force kN

IMPORTANT: The screw tightening torque M_s can be reduced by 40% of the value indicated in the table. M_t, F_{ax}, P_w, P_n decrease proportionally. For further information, please contact our Technical Department.

For larger diameters or dimensions different to those in the table, please contact us.

Application examples

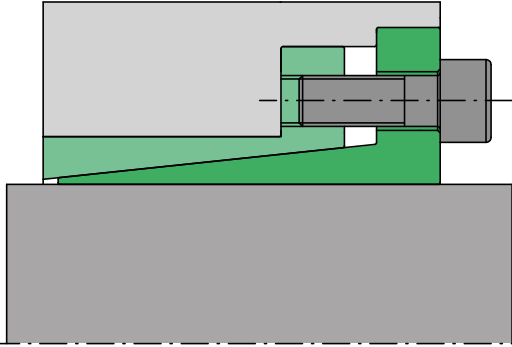

SIT-LOCK® 3 hub applications without spacer. Recommended for high rotation speeds.

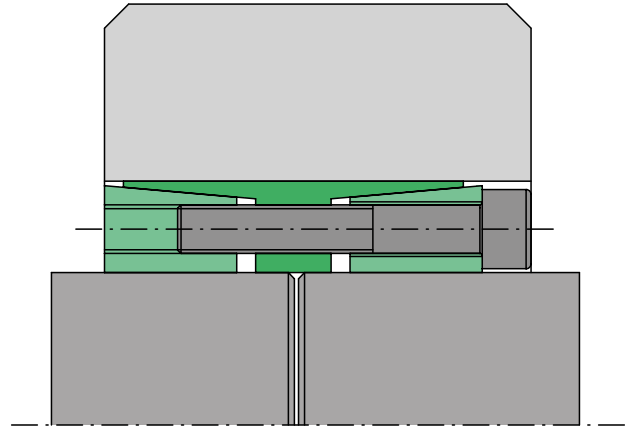

Locking two shafts and a hub using SIT-LOCK® 4. Only one locking device is used for locking 3 components.

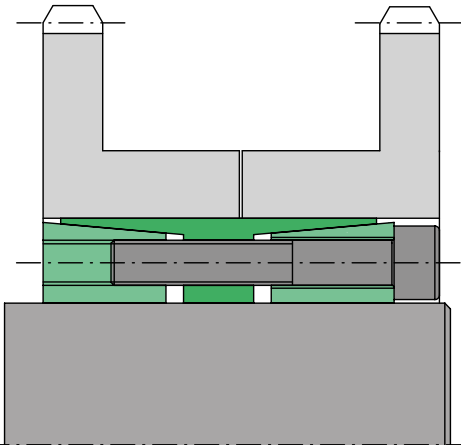

Simultaneously locking two sprockets using SIT-LOCK® 4.

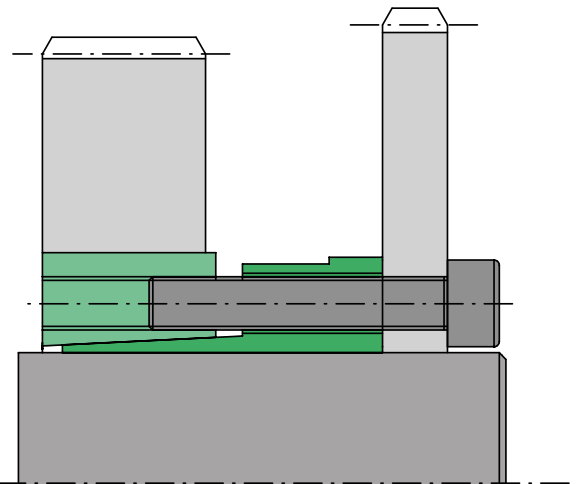

Joining a timing belt pulley and a brake disc with SIT-LOCK® 5A.

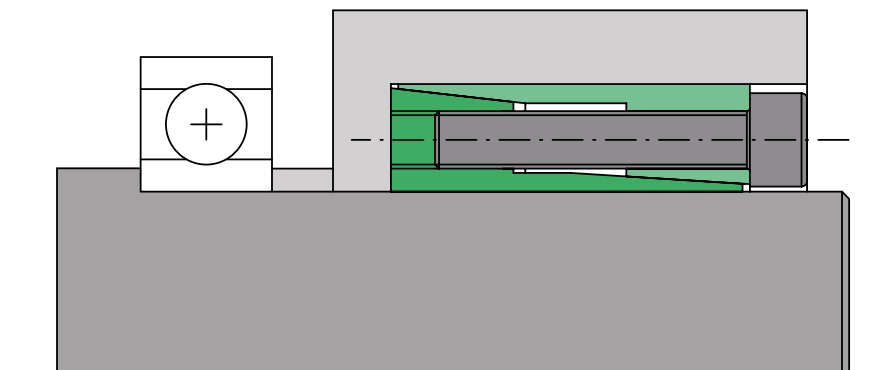

Locking a hub while also generating an axial force to axially lock a bearing.

Customised versions available on request

SIT-LOCK® 19

- Not self-centering
- High transmissible torques
- Available on request for shaft diameters of 70 to 320 mm
- No axial displacement when tightening the screws
- Quick installation and removal
- Outer diameter larger than SIT-LOCK® 4 - 4A

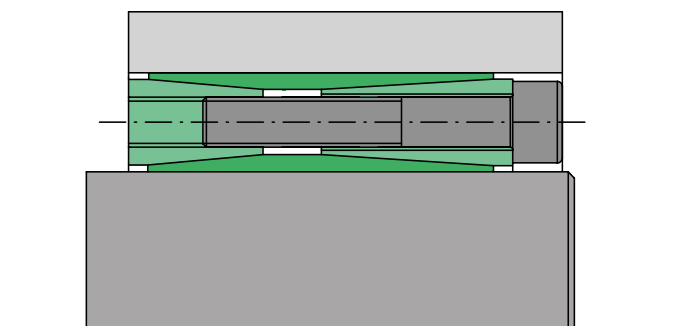

SIT-LOCK® 20

- Self-centering
- Available on request for shaft diameters of 45 to 600 mm
- No axial displacement during assembly
- Good concentricity and perpendicularity
- High transmissible torques
- **Interchangeable with SIT-LOCK® 4 - 4A in terms of both dimensions and features**

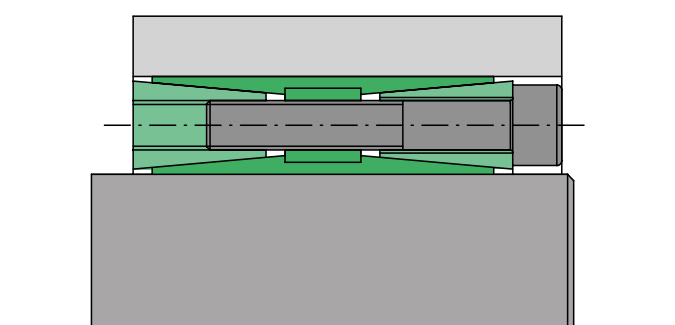

SIT-LOCK® 21

- Self-centering
- Available on request for shaft diameters of 100 to 600 mm
- No axial displacement when tightening the screws
- High transmissible torques
- Easy to remove
- **Interchangeable with SIT-LOCK® 4 - 4A in terms of both dimensions and features**

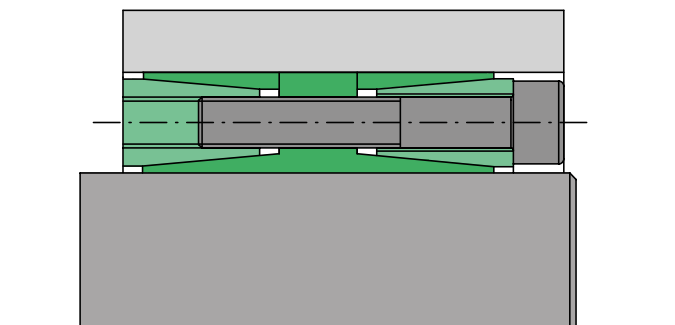

SIT-LOCK® 22

- Self-centering
- Available on request for shaft diameters of 50 to 600 mm
- No axial displacement when tightening the screws
- High transmissible torques
- Easy to remove
- Recommended for applications subject to high bending moments

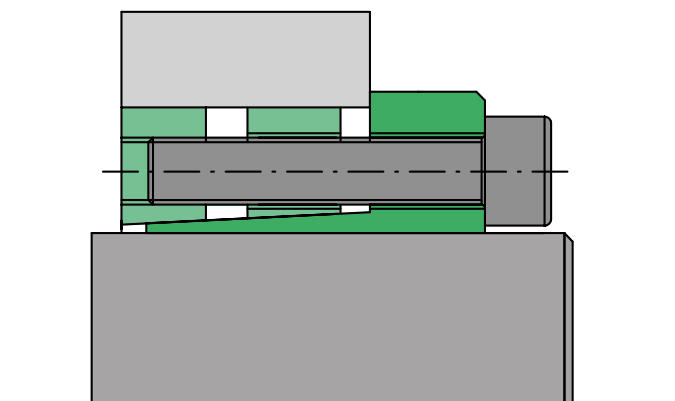

Internal - not self-centering

Customised versions available on request

SIT-LOCK® 15 special

- Excellent concentricity and perpendicularity
- Available on request for shaft diameters of 5 to 50 mm
- No axial displacement during assembly
- Low surface pressures
- Reduced axial dimensions
- Medium to high transmissible torques
- Easy to remove

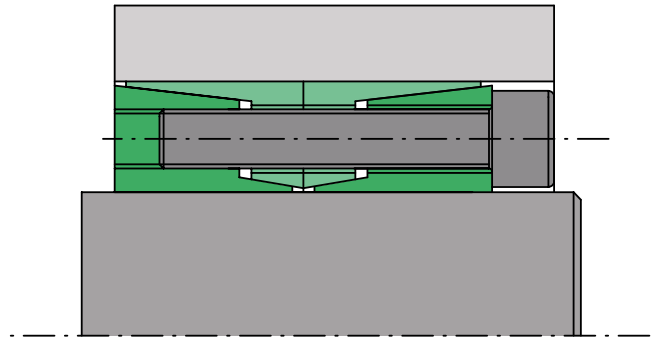

SIT-LOCK® 4 COMPACT

- For applications with high bending moments
- Quick installation and removal
- Available on request for shaft diameters of 70 to 600 mm
- No axial displacement when tightening the screws
- Excellent concentricity and perpendicularity
- Medium to high transmissible torques

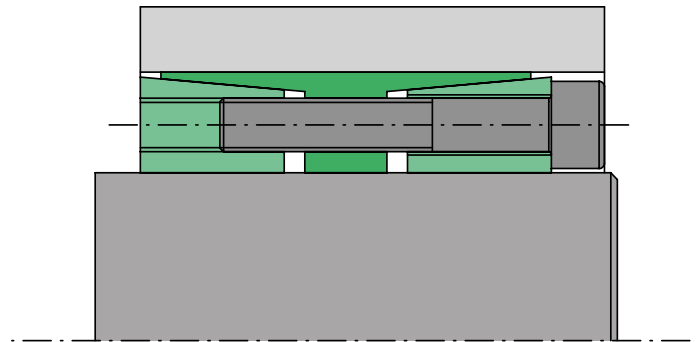

SIT-LOCK® with electroless nickel plating

- All SIT-LOCK® locking devices are available with electroless nickel plating
- M_t , F_{ax} , P_w and P_n values remain unchanged
- Excellent oxidation protection
- The screws are also supplied with electroless nickel plating
- Particularly recommended for applications in high humidity environments

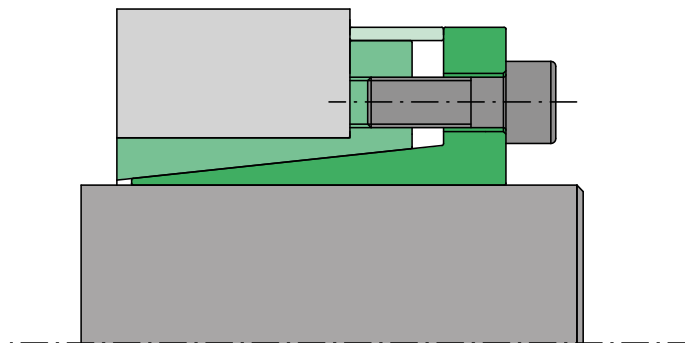

SIT-LOCK® stainless steel

- Almost all SIT-LOCK® locking devices can be manufactured and supplied in stainless steel. The screws are also supplied in stainless steel
- The values M_t , F_{ax} , P_w and P_n differ from the values in the table
- Excellent, effective oxidation protection
- Highly recommended for applications in the food industry or aggressive environments

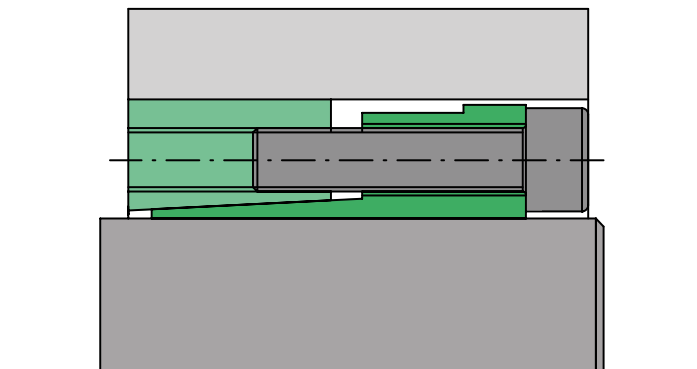

SHRINK DISC

A photograph of a shrink disc assembly, showing a metal flange with several bolts and a central ring component. The image is oriented vertically on the page.

SHRINK DISC

SIT-LOCK® 11 - shrink disc

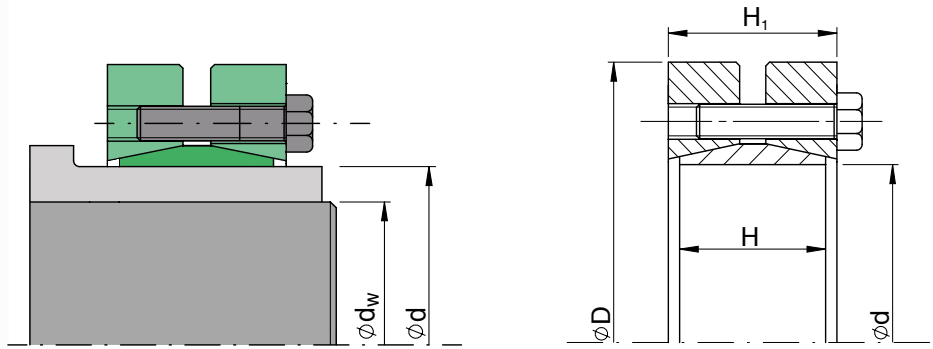

Features

Composed of a split inner ring and two outer rings without slits. Supplied with DIN 931/933 10.9 screws except for SIT-LOCK® 11S 12.9 which is supplied with DIN 912 12.9 screws.

SIT-LOCK® 11 versions

SIT-LOCK® 11S	standard series (recommended version)
SIT-LOCK® 11S 12.9	(version with DIN 912/933 12.9 screws)
SIT-LOCK® 11H	heavy duty series (for very high torques)
SIT-LOCK® 11L	light series (for low torques)

Coupling tolerances

diameter d h8

diameter d_w tolerances:

from 10 to 30 mm	H6 / j6
from 31 to 50 mm	H6 / h6
from 51 to 80 mm	H6 / g6
from 81 to 1000 mm	H7 / g6

Do not use molybdenum disulphide-based oils or greases on diameter d_w surfaces. The values shown in the table are calculated for diameter surfaces d_w when dry only, not oiled. The diameter d surface can be oiled.

Surface finish

Normal surface finish is sufficient. The following values are recommended:

$$R_a \leq 3,2 \mu\text{m} - R_t \leq 16 \mu\text{m}$$

Applications with bending moment

For applications where there is a bending moment M_f while a torque M_t is also transmitted, check that the $M_{t \text{ tot}}$ value is less than the transmissible torque indicated in the table.

$$M_{t \text{ tot}} = \sqrt{M_t^2 r^2 + 2M_f^2}$$

Applying a bending moment 30% greater than the M_t value indicated in the table is not advised.

Recommended materials for shaft d_w and hub d

The pressure generated on diameter d generates a pressure P_w on the diameter d_w , which allows the transmission of the torque M_t indicated in the table. The pressure generated on the diameter d is distributed over the surface of the diameter d_w at an angle of approximately 16°- 20°. The pressure P_w can be determined using the following formula:

$$P_w = \frac{2 \cdot M_t}{\pi \cdot d_w^2 \cdot H \cdot \mu}$$

Shaft and hub materials with a $\sigma_{0,2} \geq 360 \text{ N/mm}^2$ are recommended. For further information, please contact our Technical Department.

Installation

The SIT-LOCK® 11 locking device is supplied ready to assemble. Clean the d_w shaft contact surfaces thoroughly. Mount the locking device on the hub d and insert the shaft into the bore d_w .

Screw tightening sequence:

- tighten 2 or 4 diametrically opposed screws until the hub surfaces d_w meet;
- gradually tighten the screws until the tightening torque M_s indicated in the table is reached;
- Installation is complete when all screws are tightened to the specified tightening torque M_s .

Removal

Gradually loosen the clamping screws until the locking device is released.

Reusing the locking device

When installing or removing the locking device, check all surfaces for signs of seizing or deformation. Reapply grease to the tapered surfaces of the inner ring and the two tapered bushings, the threads and the clamping screw underheads. Use grease with a coefficient of friction μ of 0.04.

Calculating the permissible axial force

$$F_{ax} = \frac{2 M_t}{d_w}$$

SIT-LOCK® 11S - standard series

Dimensions [mm]					Transmissible torque moment M_t [Nm]	Clamping screws (DIN 931/933 - 10.9)		
d	D	d _w	H	H ₁		N°	Tipo	M _s [Nm]
14	38	11 12	7	11	32 53	4	M5	4
16	41	13 14	11	15	75 96	5	M5	4
24	50	19 20 21	14	19,5	170 210 250	6	M5	4
30	60	24 25 26	16	21,5	300 340 380	7	M5	4
36	72	28 30 31	18	23,5	440 570 630	5	M6	12
44	80	32 35 36	20	25,5	620 780 860	7	M6	12
50	90	38 40 42	22	27,5	940 1.160 1.380	8	M6	12
55	100	42 45 48	23	30,5	1.160 1.520 1.880	8	M6	12
62	110	48 50 52	23	30,5	1.750 2.000 2.250	10	M6	12
68	115	50 55 60	23	30,5	2.000 2.600 3.150	10	M6	12
75	138	55 60 65	25	32,5	2.400 3.200 3.950	7	M8	30
80	145	60 65 70	25	32,5	3.200 3.900 4.600	7	M8	30
85	155	65 70 75	30	39	4.800 6.100 7.400	10	M8	30
90	155	65 70 75	30	39	4.750 6.000 7.250	10	M8	30
95	170	70 75 80	34	44	7.000 7.650 9.150	12	M8	30
100	170	70 75 80	34	44	6.900 7.500 9.000	12	M8	30
110	185	75 80 85	39	50	7.200 9.000 10.800	9	M10	59
115	188	80 85 90	39	50	7.400 9.200 11.100	10	M10	59
120	215	80 85 90	42	54	10.600 13.300 14.500	12	M10	59
125	215	85 90 95	42	54	11.000 13.000 15.000	12	M10	59
130	215	90 95 100	42	54	11.300 13.300 15.400	12	M10	59
140	230	95 100 105	46	60,5	15.100 17.600 20.100	10	M12	100

Follow SIT-LOCK® 11S - standard series

Dimensions [mm]					Transmissible torque moment M_t [Nm]	Clamping screws (DIN 931/933 - 10.9)		
d	D	d_w	H	H_1		Number	Type	M_s [Nm]
155	265	105 110 115	50	64,5	22.000 25.000 28.000	12	M12	100
165	290	115 120 125	56	71	31.000 35.000 39.000	8	M16	250
175	300	125 130 135	56	71	36.000 41.000 45.000	8	M16	250
185	330	135 140 145	71	86	52.000 57.000 62.000	10	M16	250
195	350	140 150 155	71	86	65.000 76.000 81.500	12	M16	250
200	350	150 155 160	71	86	74.000 80.000 86.000	12	M16	250
220	370	160 165 170	88	104	95.000 102.000 110.000	15	M16	250
240	405	170 180 190	92	109	120.000 138.000 156.000	12	M20	490
260	430	190 200 210	103	120	164.000 184.000 205.000	14	M20	490
280	460	210 220 230	114	134	217.000 244.000 270.000	16	M20	490
300	485	230 240 245	122	142	275.000 295.000 315.000	18	M20	490
320	520	240 250 260	122	142	312.000 340.000 374.000	20	M20	490
340	570	250 260 270	134	156	390.000 422.500 460.000	24	M20	490
350	580	270 280 285	140	162	442.000 480.000 500.000	24	M20	490
360	590	280 290 295	140	162	463.000 502.000 522.000	24	M20	490
380	645	290 300 310	144	168	567.000 610.000 658.000	20	M24	840
390	660	300 310 320	144	168	624.000 671.000 718.000	21	M24	840
400	680	315 320 330	144	168	670.000 695.000 744.000	21	M24	840
420	690	330 340 350	164	188	780.000 840.000 900.000	24	M24	840
440	750	340 350 360	177	202	806.000 860.000 917.000	24	M24	840
460	770	360 370 380	177	202	1.000.000 1.070.000 1.140.000	28	M24	840
480	800	380 390 400	188	213	1.170.000 1.240.000 1.310.000	30	M24	840

SIT-LOCK® 11S 12.9 - version with DIN 912/933 12.9 screws

Dimensions [mm]					Transmissible torque moment	Clamping screws (DIN 912/931/933 - 12.9)		
d	D	d _w	H	H ₁	M _t [Nm]	Number	Type	M _s [Nm]
24	50	19 20 21	14	19,5	245 285 325	6	M5	4
30	60	24 25 26	16	21,5	375 415 465	7	M5	4
36	72	28 30 31	18	23,5	910 1.000 1.100	5	M6	14
44	80	32 35 36	20	25,5	1.250 1.600 1.680	7	M6	14
50	90	38 40 42	22	27,5	1.830 2.070 2.350	8	M6	14
55	100	42 45 48	23	30,5	2.020 2.400 2.850	8	M6	14
62	110	48 50 52	23	30,5	3.030 3.190 3.540	10	M6	14
68	115	50 55 60	23	30,5	2.700 3.500 4.420	10	M6	14
75	138	55 60 65	25	32,5	4.100 5.120 6.290	7	M8	35
80	145	60 65 70	25	32,5	4.620 5.690 6.870	7	M8	35
90	155	65 70 75	30	39	6.950 8.350 9.890	10	M8	35
100	170	70 75 80	34	44	8.630 10.250 12.000	12	M8	35
110	185	75 80 85	39	50	11.060 12.940 14.300	9	M10	72
125	215	85 90 95	42	54	16.200 18.700 21.450	12	M10	72
140	230	95 100 105	46	60,5	22.400 25.420 28.680	10	M12	120
155	265	105 110 115	50	64,5	30.120 33.750 37.550	12	M12	120
165	290	115 120 125	56	71	44.500 48.450 53.450	8	M16	300
175	300	125 130 135	56	71	49.200 54.100 59.200	8	M16	300
185	330	135 140 145	71	86	68.300 74.600 81.150	10	M16	300
195	350	140 150 155	71	86	86.650 100.200 107.100	12	M16	300
200	350	150 155 160	71	86	95.750 102.550 109.500	12	M16	300

Follow SIT-LOCK® 11S 12.9 - version with DIN 912/933 12.9 screws

Dimensions [mm]					Transmissible torque moment	Clamping screws (DIN 912/931/933 - 12.9)		
d	D	d _w	H	H ₁	M _t [Nm]	Number	Type	M _s [Nm]
220	370	160 165 170	88	104	124.400 134.500 144.980	15	M16	300
240	405	170 180 190	92	109	157.200 177.200 200.850	12	M20	580
260	430	190 200 210	103	120	211.650 238.300 266.600	14	M20	580
280	460	210 220 230	114	134	278.800 303.800 329.100	16	M20	580
300	485	230 240 245	122	142	349.800 378.000 394.500	18	M20	580
320	520	240 250 260	122	142	404.500 430.900 463.300	20	M20	580
340	570	250 260 270	134	156	499.600 537.300 575.650	24	M20	580
350	580	270 280 285	140	162	550.900 589.400 612.800	24	M20	580
360	590	280 290 295	140	162	573.200 612.000 635.700	24	M20	580
380	645	290 300 310	144	168	715.000 760.800 807.200	20	M24	1000
390	660	300 310 320	144	168	782.100 830.200 874.000	21	M24	1000
400	680	315 320 330	144	168	829.000 853.000 903.000	21	M24	1000
420	690	330 340 350	164	188	987.000 1.043.200 1.100.700	24	M24	1000
440	750	340 350 360	177	202	1.002.800 1.060.400 1.119.000	24	M24	1000
460	770	360 370 380	177	202	1.261.000 1.328.000 1.395.300	28	M24	1000
480	800	380 390 400	188	213	1.434.000 1.506.300 1.580.000	30	M24	1000

SIT-LOCK® 11H - heavy duty series

Dimensions [mm]					Transmissible torque moment M_t [Nm]	Clamping screws (DIN 931/933 - 10.9)		
d	D	d _w	H	H ₁		Number	Type	M _s [Nm]
125	215	85 90 95	55	65	15.000 17.500 20.000	10	M12	100
140	230	95 100 105	60	74	20.600 23.500 26.500	12	M12	100
155	265	105 110 115	66	80	28.600 32.500 36.400	15	M12	100
165	290	115 120 125	72	88	41.000 46.000 50.700	10	M16	250
175	300	125 130 135	72	88	47.000 52.000 57.000	10	M16	250
185	330	135 140 145	92	112	72.000 78.000 86.000	14	M16	250
195	350	140 150 155	92	112	75.000 88.000 96.000	14	M16	250
200	350	145 150 155	92	112	85.000 92.500 100.000	15	M16	250
220	370	160 165 170	114	134	127.000 136.000 146.500	20	M16	250
240	405	170 180 190	120	144	155.000 176.000 198.000	15	M20	490
260	430	190 200 210	136	160	213.000 240.000 268.000	18	M20	490
280	460	210 220 230	148	172	285.000 320.000 355.000	21	M20	490
300	485	230 240 245	152	176	341.000 376.000 394.000	22	M20	490
320	520	240 250 260	160	184	378.500 415.000 451.000	24	M20	490
340	570	250 260 270	176	200	489.500 530.000 578.000	21	M24	840
350	580	270 280 285	176	200	556.000 604.000 629.000	21	M24	840
360	590	280 290 295	180	204	612.000 663.000 689.000	22	M24	840
380	645	290 300 310	180	204	618.000 668.000 719.000	22	M24	840
390	660	300 310 320	188	212	708.000 762.000 814.500	24	M24	840
400	680	315 320 330	188	212	765.000 788.000 845.000	24	M24	840
420	690	330 340 350	214	238	999.000 1.068.000 1.140.000	30	M24	840
440	750	340 350 360	224	252	1.058.000 1.130.000 1.204.000	24	M27	1.250
460	770	360 370 380	224	252	1.320.000 1.420.000 1.500.000	28	M27	1.250

SIT-LOCK® 11L - light series

Dimensions [mm]					Transmissible torque moment	Clamping screws (DIN 931/933 - 10.9)		
d	D	d _w	H	H ₁	M _t [Nm]	Number	Type	M _s [Nm]
125	185	95 100 105	39	51	10.550 12.100 13.800	8	M10	59
140	220	110 120 125	39	51	14.800 18.640 20.500	9	M10	59
155	245	130 135 140	39	51	24.000 26.400 29.000	11	M10	59
165	260	135 140 145	46	62	32.000 35.200 38.500	10	M12	100
175	275	145 150 155	46	62	39.000 42.400 46.000	11	M12	100
185	295	155 160 165	46	62	46.600 50.300 54.000	12	M12	100
195	315	165 170 175	56	72	63.000 67.700 72.500	15	M12	100
200	330	175 180 185	56	72	74.000 79.500 84.500	16	M12	100
220	345	180 190 200	66	84	82.800 93.500 105.000	10	M16	250
240	370	200 210 215	66	84	113.000 127.500 134.500	12	M16	250
260	395	220 230 235	72	92	149.000 165.000 173.000	14	M16	250
280	425	230 240 250	84	104	171.000 189.000 208.000	16	M16	250
300	460	250 260 270	84	104	215.000 234.000 255.000	18	M16	250
320	495	270 280 290	84	106	260.000 284.000 306.000	20	M16	250
340	535	290 300 305	84	106	300.000 324.400 337.000	21	M16	250
350	545	300 305 310	100	122	372.000 385.000 400.000	16	M20	490
360	555	300 310 320	100	122	360.000 388.000 415.000	16	M20	490
380	585	320 325 330	112	136	435.000 451.000 467.000	18	M20	490
390	595	330 340 350	112	136	505.000 540.000 577.000	20	M20	490
400	615	340 350 360	112	136	550.000 587.000 626.000	21	M20	490
420	630	350 360 370	120	144	578.000 617.000 655.000	22	M20	490
440	660	370 380 390	120	144	677.000 719.000 762.000	24	M20	490
460	685	390 400 410	132	158	840.000 890.000 935.000	28	M20	490

SIT-LOCK® 14 - shrink disc

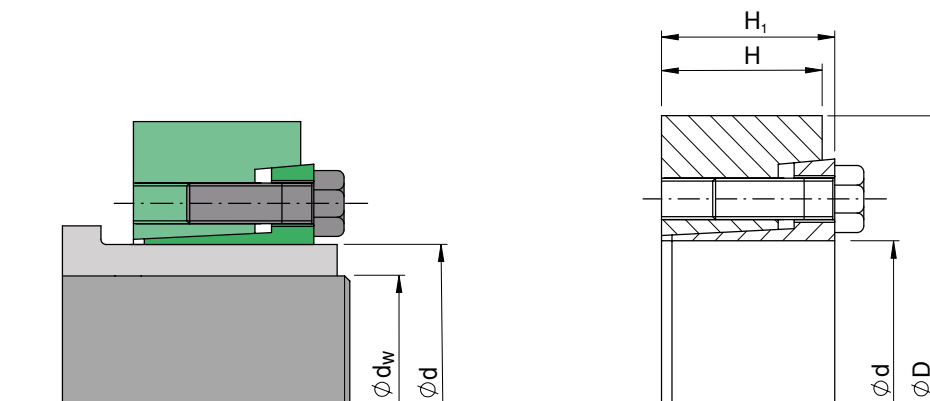

Features

Composed of an inner ring and an outer ring. Comes with DIN 931/933 10.9 or 12.9 screws depending on the model.

SIT-LOCK® 14 versions

SIT-LOCK® 1422-1481	standard series (recommended version)
SIT-LOCK® 1423-1483	heavyweight series for high torque
SIT-LOCK® 1421	lightweight series for low torque

Coupling tolerances

diameter d f7

diameter d_w tolerances

≤ 160 mm	H7 / h6
≥ 160 mm	H7 / g6

Do not use molybdenum disulphide-based oils or greases on diameter d_w surfaces. The values shown in the table are calculated for diameter surfaces d_w when dry only, not oiled. The diameter d surface can be oiled.

Surface finish

Normal surface finish is sufficient. The following values are recommended:

$$R_a \leq 3,2 \mu\text{m} - R_t \leq 16 \mu\text{m}$$

Applications with bending moment

For applications where there is a bending moment M_f while a torque M_t is also transmitted, check that the $M_{t \text{ tot}}$ value is less than the transmissible torque indicated in the table.

$$M_{t \text{ tot}} = \sqrt{M_t^2 r^2 + 2M_f^2}$$

Applying a bending moment 30% greater than the M_t value indicated in the table is not advised.

Recommended materials for shaft d_w and hub d

The pressure generated on diameter d generates a pressure P_w on the diameter d_w , which allows the torque transmission M_t indicated in the table. The pressure generated on the diameter d is distributed over the surface of the diameter d_w at an angle of approximately 16°- 20°. The pressure P_w can be determined using the following formula:

$$P_w = \frac{2 \cdot M_t}{\pi \cdot d_w^2 \cdot H \cdot \mu}$$

Shaft and hub materials with a $\sigma_{0,2} \geq 360$ N/mm² are recommended. For applications subject to bending moments, using tempered shafts is recommended, such as steel 42 CrMo4. For further information or confirmation, please contact our Technical Department.

Advantages of SIT-LOCK® 14 compared to SIT-LOCK® 11

The SIT-LOCK® 14 locking device can be installed even without a torque wrench. It is important that the flat surface of the inner ring aligns with the flat surface of the outer ring when installation is complete.

See figure:

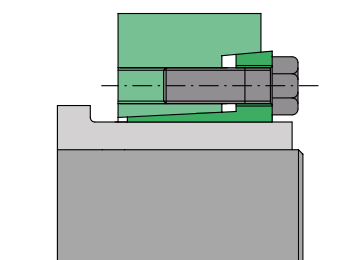

SIT-LOCK® 14 not assembled

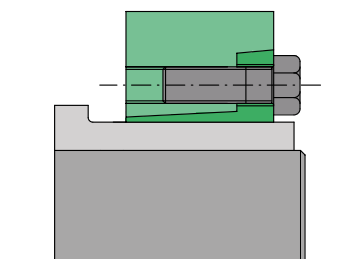

SIT-LOCK® 14 assembled

When the two components' surfaces are aligned, installation is complete and the values indicated in the table will have been achieved.

Since the clamping screws are not typically tightened using a torque wrench, the values indicated in the table are often not reached. In these cases, slippage could occur resulting in economic damages.

The SIT-LOCK® 14 internal locking device should be considered the most effective development in the field of friction shaft-hub couplings as it can be assembled without using a torque wrench and, thanks to the alignment, still guarantees simple, functional installation.

Installation

The SIT-LOCK® 14 locking device is supplied ready to assemble. Clean the d_w shaft contact surfaces thoroughly. The contact surface of diameter d_w must be dry, without any traces of oil. The transmissible torque M_t is calculated with a coefficient of friction μ equal to 0.15. Mount the locking device on the hub d and insert the shaft into the bore d_w .

Caution: Do not tighten the screws before placing the locking device on the hub.

Clean the diameter d contact surface and apply a light film of oil to facilitate the locking device's positioning.

Installation without torque wrench

- tighten 2 or 4 diametrically opposed screws until the diameter d_w contact surfaces are locked
- gradually tighten the screws clockwise until the lateral surfaces of the inner and outer ring are completely aligned
- Installation is complete once alignment has been achieved

Installation with torque wrench

- tighten 2 or 4 diametrically opposed screws until the diameter d_w contact surfaces are locked. This does not require a torque wrench;
- tighten the screws clockwise, in continuous sequence, to 50% of the M_s tightening torque indicated in the table;
- tighten the screws clockwise, in continuous sequence, to 100% of the M_s tightening torque indicated in the table;
- continue tightening the screws clockwise, in continuous sequence, to 100% of the M_s tightening torque indicated in the table until alignment is achieved.

Removal

Loosen the screws in a continuous sequence until the locking device is fully removed. If the locking device does not disassemble after all screws have been loosened, insert the clamping screws into the removal threads on the inner ring. Tighten the screws in a 'criss-cross' sequence until the locking device is released.

Reusing the locking device

When installing or removing the locking device, check all surfaces for signs of seizing or deformation. Reapply grease to the tapered surfaces of the inner ring and outer ring, the threads and the clamping screw underheads. Use grease with a coefficient of friction μ of 0.04. For further information, please contact our Technical Department.

High speed applications

For applications that require greater balance, SIT-LOCK® 14 is recommended rather than SIT-LOCK® 11, as incorrect parallelism may create issues at high rotation speeds.

SIT-LOCK® 1422 - 1481 shrink disc

Dimensions [mm]					SIT-LOCK® 1422		SIT-LOCK® 1481		Clamping screws DIN 933/931 10.9 (1422) 12.9 (1481)
d	D	d _w	H	H ₁	M _t [Nm]	M _s [Nm]	M _t [Nm]	M _s [Nm]	
12	35	9	10	11	20	12	-	-	M6
		10			40		-		
14	38	11	10	11	30	12	-	-	M6
		12			50		-		
16	41	13	13,5	15	70	12	-	-	M6
		14			90		-		
18	44	15	13,5	15	80	12	-	-	M6
		16			110		-		
20	47	17	13,5	15	150	12	-	-	M6
		18			180		-		
24	50	19	16	18	160	12	-	-	M6
		20			210		-		
30	60	22	18	20	280	12	-	-	M6
		24			270		-		
36	72	25	20	22	320	30	-	-	M8
		26			360		-		
44	80	27	22	24	440	30	-	-	M8
		30			610		-		
50	90	33	23,5	26	820	30	-	35	M8
		34			690		-		
55	100	35	26	29	770	30	-	35	M8
		37			920		-		
62	110	38	26	29	1.110	30	1.500	35	M8
		40			1.290		1.700		
68	115	42	26	29	1.510	30	1.900	35	M8
		44			1.230		1.600		
75	138	45	27	31	1.530	59	2.000	70	M10
		48			1.860		2.400		
80	145	48	27	31	1.670	59	2.200	70	M10
		50			1.890		2.400		
90	155	52	34	38	2.120	59	2.700	70	M10
		55			1.870		2.400		
100	170	55	39	43	2.450	59	3.000	70	M10
		60			3.120		3.800		
110	185	65	43,5	49	2.330	100	3.700	121	M10
		60			3.020		4.700		
120	197	65	46,5	53	3.810	100	5.800	121	M12
		70			4.910		6.300		
125	215	75	46,5	53	5.400	100	5.900	121	M12
		77			6.500		7.100		
130	215	80	46,5	53	7.800	100	8.500	121	M12
		80			6.000		7.400		
135	230	85	49,5	58	7.200	160	8.900	195	M14
		80			10.000		12.600		
140	230	90	49,5	58	11.700	160	14.600	195	M14
		90			13.600		16.900		
155	263	95	53,5	62	11.900	160	13.600	195	M14
		95			13.800		15.700		
165	290	95	58	68	15.900	250	18.000	300	M16
		95			14.400		16.400		
175	300	100	58	68	16.500	250	18.800	300	M16
		100			18.700		21.300		
175	300	110	58	68	14.100	250	16.000	300	M16
		95			16.100		18.400		
175	300	100	58	68	18.300	250	20.800	300	M16
		95			18.100		20.300		
175	300	110	58	68	20.600	250	23.000	300	M16
		110			26.000		28.900		
175	300	115	58	68	19.600	250	23.000	300	M16
		105			22.100		25.800		
175	300	115	58	68	27.600	250	32.100	300	M16
		115			26.500		31.100		
175	300	125	58	68	29.500	250	34.500	300	M16
		125			36.100		42.000		
175	300	135	58	68	37.300	250	44.000	300	M16
		120			41.200		48.500		
175	300	130	58	68	49.600	250	58.100	300	M16
		130			45.000		54.000		
175	300	145	58	68	49.000	250	59.000	300	M16
		135			58.000		70.000		

Follow SIT-LOCK® 1422 - 1481 shrink disc

Dimensions [mm]						SIT-LOCK® 1422			SIT-LOCK® 1481			Clamping screws DIN 933/931 10.9 (1422) 12.9 (1481)
d	D	d _w	H	H ₁	e	M _t [Nm]	F _{ax} [kN]	M _s [Nm]	M _t [Nm]	F _{ax} [kN]	M _s [Nm]	
185	320	140	75	85	10	64.000	916	250	81.000	1.157	300	M16
		145				70.000	961		88.000	1.210		
		155				82.000	1.053		102.000	1.319		
200	340	150	75	85	10	81.000	1.073	250	96.000	1.279	300	M16
		155				87.000	1.120		103.000	1.333		
		165				100.000	1.216		119.000	1.442		
220	370	160	91	103	12	103.000	1.283	490	129.000	1.615	570	M20
		170				119.000	1.395		149.000	1.749		
		180				136.000	1.509		169.000	1.883		
240	405	170	94	107	13	122.000	1.439	490	151.000	1.773	570	M20
		180				140.000	1.555		172.000	1.909		
		200				179.000	1.790		218.000	2.183		
260	430	190	105	119	14	163.000	1.715	490	212.000	2.231	570	M20
		200				184.000	1.842		238.000	2.385		
		220				231.000	2.099		297.000	2.696		
280	460	210	116	132	16	215.000	2.051	490	279.000	2.661	570	M20
		220				240.000	2.186		311.000	2.825		
		240				295.000	2.458		379.000	3.156		
300	485	220	124	140	16	270.000	2.456	840	332.000	3.018	980	M24
		230				300.000	2.605		367.000	3.193		
		250				363.000	2.906		443.000	3.545		
320	520	240	124	140	16	301.000	2.511	840	404.000	3.370	980	M24
		250				332.000	2.655		444.000	3.549		
		270				398.000	2.945		528.000	3.911		
340	570	250	137	155	18	390.000	3.118	840	488.000	3.905	980	M24
		260				427.000	3.283		533.000	4.101		
		280				506.000	3.617		630.000	4.498		
350	580	270	142	162	20	493.000	3.649	840	616.000	4.563	980	M24
		280				535.000	3.825		669.000	4.778		
		290				580.000	4.001		725.000	5.000		
360	590	270	142	162	20	496.000	3.676	840	625.000	4.628	980	M24
		280				539.000	3.852		677.000	4.839		
		300				631.000	4.206		790.000	5.264		
380	640	290	146	166	20	585.000	4.034	1.250	725.000	5.000	1.450	M27
		300				632.000	4.215		783.000	5.220		
		310				681.000	4.397		844.000	5.445		
390	650	290	146	166	20	640.000	4.411	1.250	781.000	5.384	1.450	M27
		300				691.000	4.605		842.000	5.611		
		320				799.000	4.996		971.000	6.069		
420	670	320	166	186	20	742.000	4.640	1.250	969.000	6.057	1.450	M27
		330				797.000	4.829		1.038.000	6.290		
		350				912.000	5.209		1.183.000	6.758		
440	720	340	174	194	20	945.000	5.557	1.250	1.212.000	7.128	1.450	M27
		350				1.009.000	5.764		1.292.000	7.382		
		370				1.143.000	6.181		1.460.000	7.891		
460	770	360	174	194	20	1.104.000	6.133	1.250	1.393.000	7.739	1.450	M27
		370				1.174.000	6.345		1.479.000	7.995		
		390				1.320.000	6.771		1.660.000	8.511		
480	800	380	191	213	22	1.300.000	6.843	1.640	1.657.000	8.721	1.970	M30
		390				1.378.000	7.066		1.754.000	8.993		
		410				1.541.000	7.516		1.956.000	9.542		
500	850	400	191	213	22	1.496.000	7.478	1.640	1.887.000	9.435	1.970	M30
		410				1.581.000	7.711		1.992.000	9.717		
		430				1.759.000	8.180		2.211.000	10.283		
530	910	430	216	238	22	1.930.000	8.976	1.640	2.397.000	11.150	1.970	M30
		440				2.031.000	9.234		2.521.000	11.459		
		460				2.243.000	9.752		2.778.000	12.078		
560	940	450	216	238	22	2.097.000	9.318	1.640	2.545.000	11.313	1.970	M30
		460				2.201.000	9.572		2.671.000	11.611		
		480				2.420.000	10.081		2.930.000	12.210		
590	960	470	235	260	25	2.593.000	11.032	1.640	2.969.000	12.636	1.970	M30
		480				2.715.000	11.314		3.108.000	12.952		
		500				2.970.000	11.881		3.397.000	13.587		
620	980	500	261	286	25	2.940.000	11.760	1.640	3.602.000	13.608	1.970	M30
		520				3.169.000	12.188		3.708.000	14.261		
		540				3.447.000	12.766		4.028.000	14.918		
660	1020	530	270	292	20	3.329.500	12.564	2.210	4.035.000	15.225	2.400	M33
		550				3.615.000	13.145		4.374.000	15.905		
		570				3.912.000	13.726		4.727.000	16.585		

SIT-LOCK® 1423 - 1483 shrink disc

Dimensions [mm]					SIT-LOCK® 1423		SIT-LOCK® 1483		Clamping screws DIN 931 1423 10.9 - 1483 12.9
d	D	d _w	H	H ₁	M _t [Nm]	M _s [Nm]	M _t [Nm]	M _s [Nm]	
140	230	100	64	74	26.000	250	30.000	300	M16
		105			30.000		34.000		
		115			37.000		42.000		
155	263	110	70	80	36.000	250	45.000	300	M16
		115			40.000		49.000		
		125			48.000		60.000		
165	290	120	77	88	50.000	250	63.000	300	M16
		125			55.000		69.000		
		135			66.000		83.000		
175	300	130	77	88	61.000	250	73.000	300	M16
		135			67.000		80.000		
		145			79.000		94.000		
185	320	140	100	112	89.000	490	106.000	570	M20
		145			96.000		115.000		
		155			113.000		134.000		
200	340	150	100	112	104.000	490	126.000	570	M20
		155			113.000		136.000		
		165			130.000		157.000		
220	370	160	121	134	127.000	490	162.000	570	M20
		165			137.000		174.000		
		180			169.000		213.000		
240	405	170	130	144	157.000	490	206.000	570	M20
		180			180.000		235.000		
		200			230.000		298.000		
260	430	190	144	160	230.000	490	285.000	570	M20
		200			260.000		321.000		
		220			325.000		399.000		
280	460	210	156	172	306.000	840	361.000	980	M24
		220			342.000		401.000		
		240			418.000		489.000		
300	485	230	158	176	360.000	840	461.000	980	M24
		240			398.000		508.000		
		250			437.000		556.000		
320	520	240	166	184	430.000	840	512.000	980	M24
		250			473.000		562.000		
		270			565.000		670.000		
340	570	250	186	206	551.000	1250	661.000	1.450	M27
		260			603.000		722.000		
		280			714.000		852.000		
360	590	270	188	210	671.000	1250	763.000	1.450	M27
		280			729.000		828.000		
		300			852.000		966.000		
390	650	290	196	220	850.000	1250	978.000	1.450	M27
		300			917.000		1.054.000		
		320			1.061.000		1.217.000		
420	690	320	221	246	1.007.000	1250	1.297.000	1.450	M27
		330			1.080.000		1.389.000		
		350			1.235.000		1.582.000		
440	750	340	233	258	1.218.000	1640	1.583.000	1.970	M30
		350			1.301.000		1.687.000		
		370			1.475.000		1.907.000		
460	770	360	233	258	1.402.000	1640	1.734.000	1.970	M30
		370			1.491.000		1.841.000		
		390			1.678.000		2.067.000		
480	800	380	270	298	1.707.000	1640	2.076.000	1.970	M30
		390			1.809.000		2.198.000		
		410			2.023.000		2.452.000		
500	850	400	270	300	1.993.000	1640	2.529.000	1.970	M30
		410			2.106.000		2.669.000		
		430			2.342.000		2.962.000		
530	890	430	306	338	2.549.000	2210	3.093.000	2.650	M33
		440			2.683.000		3.252.000		
		460			2.962.000		3.584.000		
560	940	450	306	338	2.837.000	2210	3.439.000	2.650	M33
		460			2.978.000		3.607.000		
		480			3.272.000		3.956.000		

SIT-LOCK® 1421 shrink disc

Dimensions [mm]					Transmissible torque moment	Clamping screws (DIN 933 - 10,9)	
d	D	d _w	H	H ₁	M _t [Nm]	Tipo	M _s [Nm]
140	215	110	38	46	16.000	M12	100
		120			20.000		
		130			25.000		
155 160	245	130	38	46	26.000	M12	100
		135			28.000		
		140			31.000		
165 170	263	135	43	53	29.000	M14	160
		140			32.000		
		145			35.000		
175 180	275	145	43	53	36.000	M14	160
		150			39.000		
		155			42.000		
185 190	290	155	51	62	50.000	M14	160
		160			54.000		
		165			58.000		
195 200	320	165	51	62	68.000	M14	160
		170			73.000		
		180			83.000		
220	340	180	55	70	80.000	M16	240
		190			91.000		
		200			103.000		
240	370	200	55	70	103.000	M16	240
		210			115.000		
		220			128.000		
260	405	220	55	70	132.000	M16	240
		230			146.000		
		240			161.000		
280	430	230	65	80	160.000	M20	470
		240			177.000		
		250			194.000		
300	460	250	65	80	191.000	M20	470
		260			209.000		
		270			228.000		
320	485	270	77	92	243.000	M20	470
		280			265.000		
		290			288.000		
340	520	280	77	92	274.000	M20	470
		290			297.000		
		300			322.000		
360	570	300	89	105	356.000	M20	470
		310			384.000		
		330			443.000		
390	590	330	89	105	438.000	M20	470
		340			469.000		
		350			501.000		
420	630	350	120	140	624.000	M24	820
		360			665.000		
		370			709.000		
440	660	370	132	152	778.000	M24	820
		380			826.000		
		390			877.000		
460	690	390	132	152	852.000	M24	820
		400			903.000		
		410			955.000		
480	720	410	152	174	1.086.000	M24	820
		420			1.147.000		
		430			1.210.000		
500	745	420	152	174	1.137.000	M24	820
		430			1.200.000		
		450			1.331.000		
530	790	450	162	186	1.376.000	M27	1.210
		460			1.446.000		
		480			1.592.000		
560	830	480	162	187	1.578.000	M27	1.210
		490			1.653.000		
		510			1.809.000		
590	880	510	172	197	1.873.000	M27	1.210
		520			1.957.000		
		540			2.131.000		
620	930	540	172	198	2.097.000	M27	1.210
		550			2.186.000		
		570			2.368.000		
660	990	570	182	209	2.426.000	M30	1.640
		580			2.522.000		
		610			2.823.000		
700	1040	610	182	210	2.772.000	M30	1.640
		620			2.874.000		
		640			3.084.000		
750	1100	640	192	222	3.104.000	M30	1.640
		650			3.214.000		
		680			3.555.000		
800	1150	680	192	224	3.443.000	M30	1.640
		700			3.673.000		
		730			4.033.000		

Application examples

Simultaneously locking one gear and two shafts using SIT-LOCK® 14.

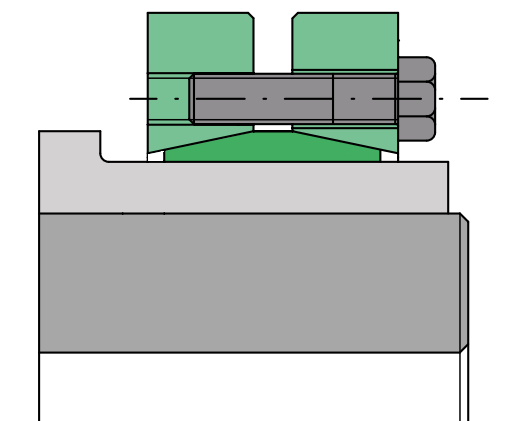
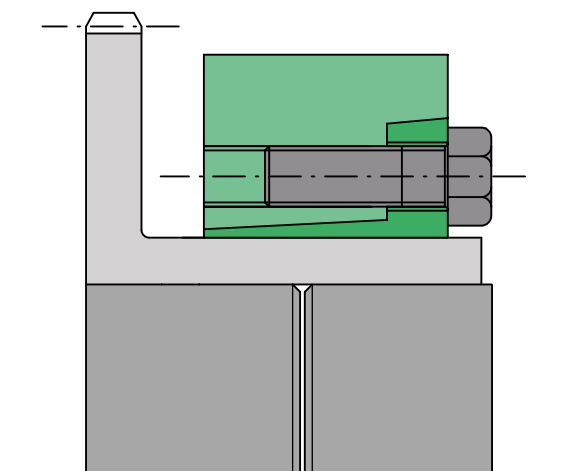

Locking a hub with its shaft using SIT-LOCK® 11. There is a bore in the shaft. For applications with shaft bore d_w , please contact our Technical Department.

Coupling two shafts and a hub using SIT-LOCK® 14.

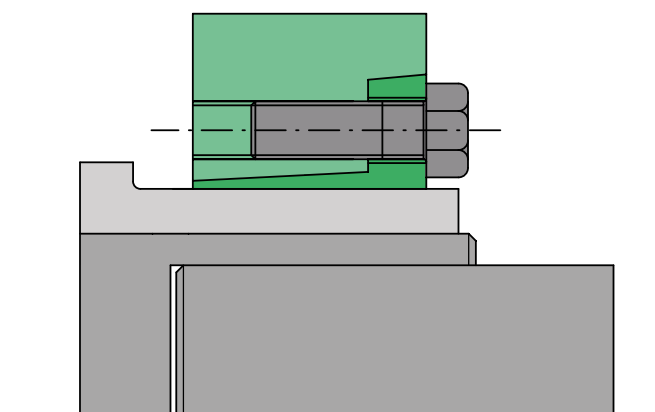

Customised versions available on request

SIT-LOCK® 11 SPLIT

- Self-centering
- High transmissible torques
- Available on request for shaft diameters of 24 to 500 mm
- No axial displacement when tightening the screws
- Quick installation and removal

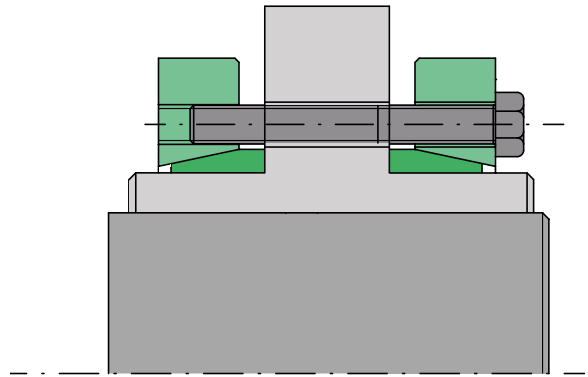

SIT-LOCK® 11 HALF version A

- Self-centering
- Medium to high transmissible torques
- Available on request for shaft diameters of 24 to 500 mm
- No axial displacement when tightening the screws
- Quick installation and removal
- Reduced axial dimensions

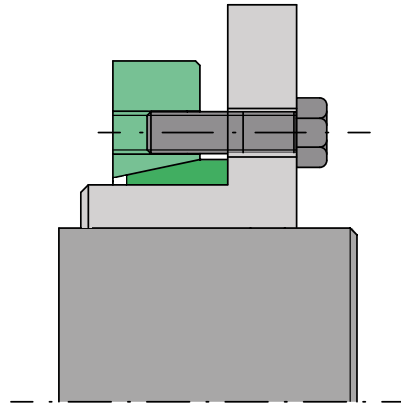

SIT-LOCK® 11 HALF version B

- Self-centering
- Medium to high transmissible torques
- Available on request for shaft diameters of 24 to 500 mm
- No axial displacement when tightening the screws
- Quick installation and removal
- Reduced axial dimensions

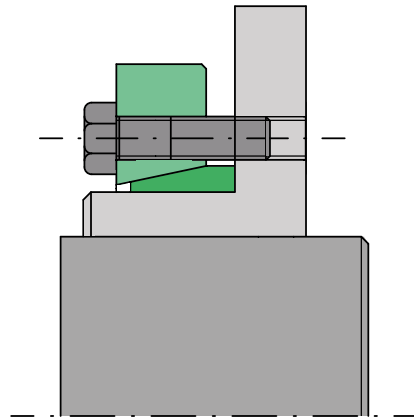

SIT-LOCK® 11 rigid joint version

- Self-centering
- Available on request for shaft diameters of 24 to 600 mm
- No axial displacement when tightening the screws
- High transmissible torques
- Easy to remove
- No backlash

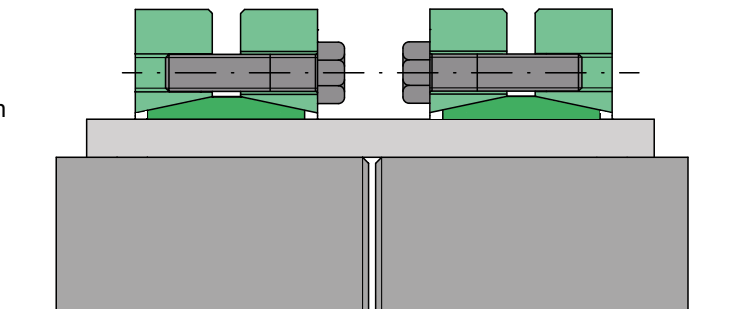

Customised versions available on request

SIT-LOCK® 14 special

- Self-centering
- Medium to high transmissible torques
- Available on request for shaft diameters of 24 to 500 mm
- No axial displacement when tightening the screws
- Quick installation and removal
- Reduced axial dimensions
- Excellent concentricity and perpendicularity

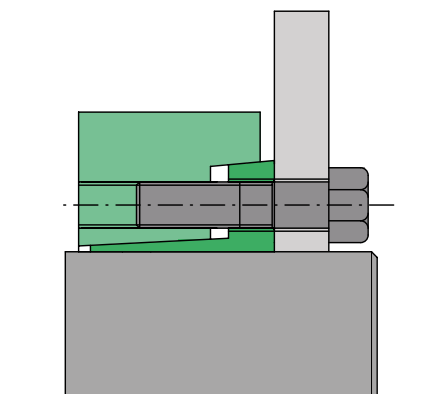

SIT-LOCK® 14 special for tight spaces

- Self-centering
- Medium to high transmissible torques
- Available on request for shaft diameters of 50 to 500 mm
- No axial displacement when tightening the screws
- Quick installation and removal
- Recommended for applications that require a reduced size
- May be supplied with DIN 912 clamping screws

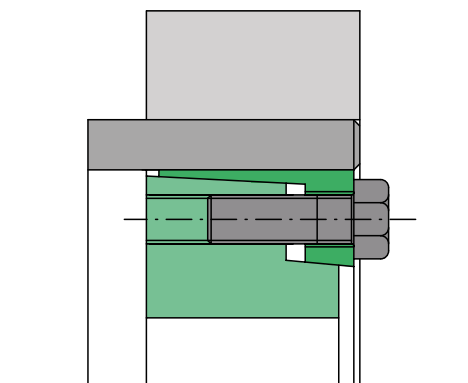

SIT-LOCK® 11, SIT-LOCK® 14 with electroless nickel plating

- SIT-LOCK® 11 and SIT-LOCK® 14 locking devices can be supplied with electroless nickel plating
- M_t , F_{ax} , P_w and P_n values remain unchanged
- Medium to high transmissible torques
- Excellent oxidation protection
- The screws are also supplied with electroless nickel plating
- Particularly recommended for applications in high humidity environments

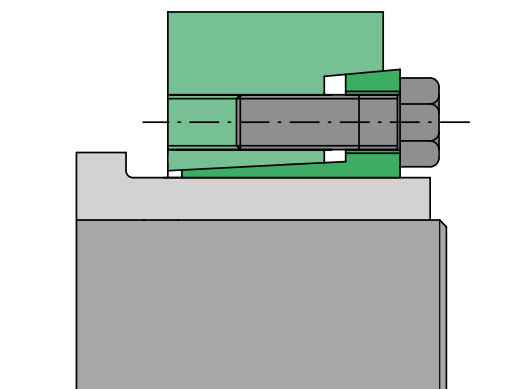

SIT-LOCK® 11, SIT-LOCK® 14 in stainless steel

- SIT-LOCK® 11 and SIT-LOCK® locking devices 14 can be manufactured and supplied in stainless steel. The screws are also supplied in stainless steel.
- The M_t , F_{ax} , P_w and P_n values are lower than those in the table
- Medium to high transmissible torques
- Highly recommended for applications in the food industry or aggressive environments
- For further information, please contact our Technical Department.

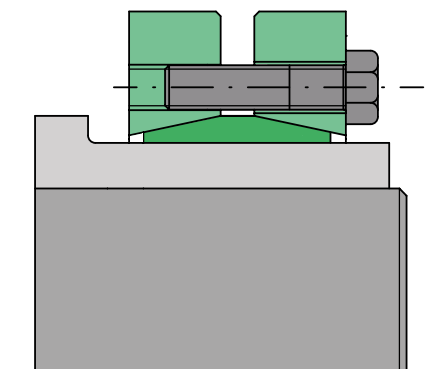

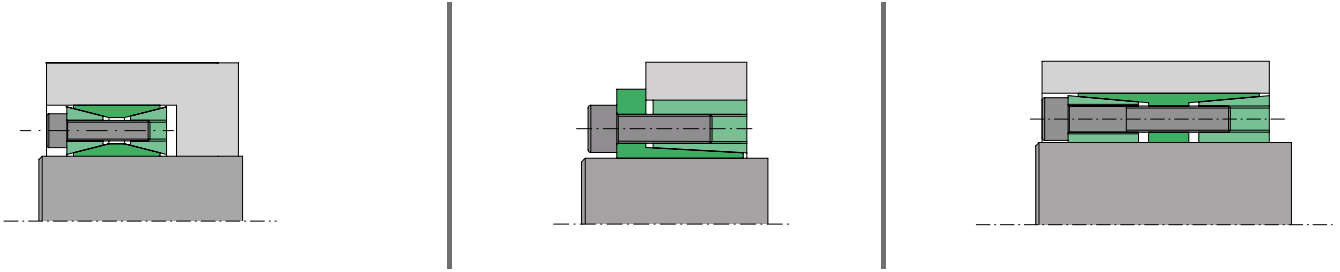

**SIT-LOCK® locking devices
for applications with high bending moments**



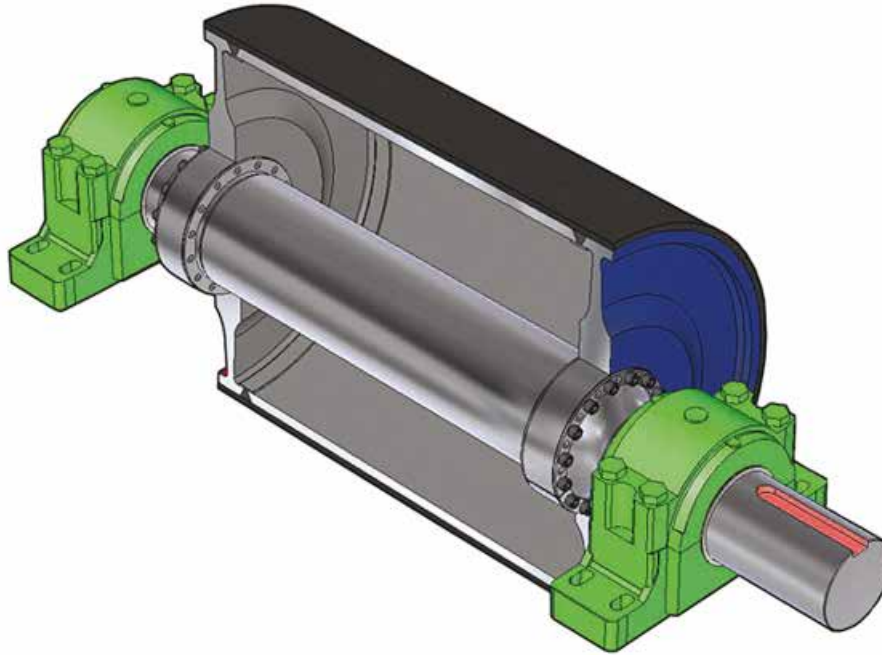

Bending moment

The bending moment in a shaft-hub coupling is a crucial factor to consider during the design phase. The figure shows an application for clamping a conveyor belt pulley. A typical application that requires simultaneous torque transmission and bending moment.

The bending moment changes the pressure the locking device generates on the shaft and hub contact surfaces.

An excessive bending moment could cause an additional load on the locking device clamping screws causing them to break if the load is excessive.

The pressure generated by the bending moment causes an increase and decrease in the pressure generated by the SIT-LOCK® locking device and may significantly affect the transmissible torque.

The sum of the static pressure generated by the locking device and the pressure generated by the bending moment, generates a minimum and maximum value. This occurs on both the shaft and hub contact surfaces.

Checking these pressures is crucial as they affect the choice of shaft diameter and correct hub sizing.

For proper use, the minimum pressure generated on the surfaces must be at least 30 N/mm² to avoid oxidation.

Lower values may cause difficulty when removing the coupling.

Transmissible torque moment

A shaft-hub coupling using SIT-LOCK® frictional locking devices can simultaneously allow a torque M_t , an axial force F_{ax} and a radial force (a force that results in a bending moment M_b). To determine the final resultant force, these values must be added together in a vector-based way.

SIT-LOCK® screw tightening torque

The screw tightening torque values are calculated taking into account a friction coefficient between the threads equal to 0.14 (oiled screws and threads).

If necessary, the tightening torque M_s in the table can be reduced. As a result, the M_t , F_{ax} , P_w and P_n values will vary proportionally. For further information, please contact our Technical Department.

Tolerances and surface finish

The values shown in the tables are valid when the correct tolerances and surface finishes are used.

Tolerances greater than those indicated can have a significant effect on the transmittable torque.

These are the recommended values:

SIT-LOCK® 1 shaft h9 - hub H9	SIT-LOCK® 7 and SIT-LOCK® 4 COMPACT shaft h8 - hub H8
surface finish of shaft and hub R_a surface finish of shaft and hub	

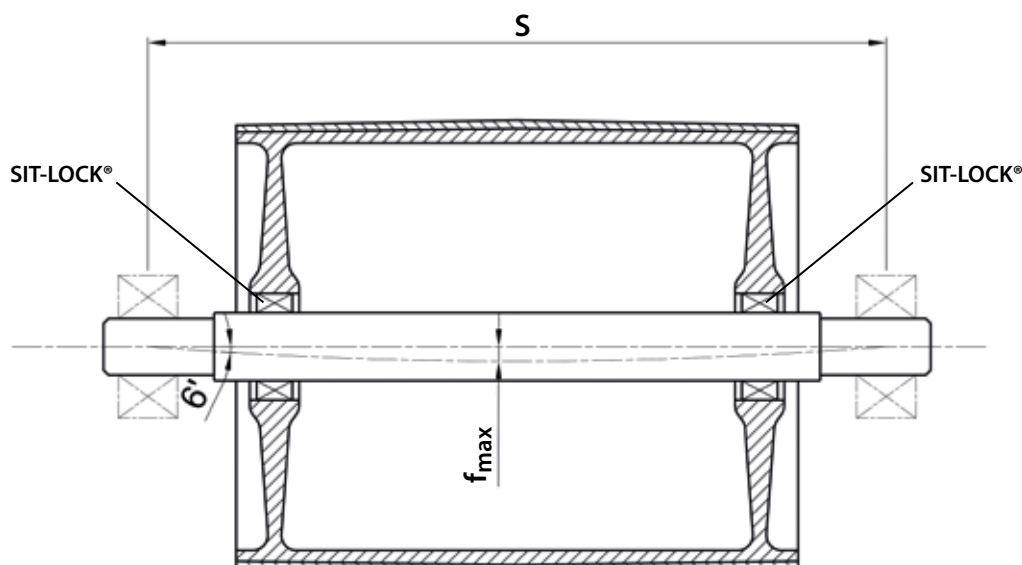

Conveyor belt pulley installed using a SIT-LOCK® locking device

First of all, the maximum bending moment of the shaft used for transmission must be checked. The permissible deflection (f_{max}) must not exceed 1/2000 of the distance between bearings (s).

Once the maximum bending moment has been checked, check which type of SIT-LOCK® should be used. The tables show the permissible values for proper use. The values shown are calculated with oiled surfaces.

Coefficient of friction taken as: 0.12

Minimum hub diameter D_{min}

The following diagram shows how to calculate the minimum hub diameter D_{min} .

To determine the minimum hub diameter D_{min} , multiply the coefficient K by the outer diameter D of the chosen SIT-LOCK® locking device.

K depends on the elastic load of the hub material (indicate letter), the pressure generated on the hub (P_n) and X which varies according to the shape of the hub (A, B, C).

Application A X=1	Application B X=0,8	Application C X=0,6

$$D_{min} \geq D \times K$$

$$K = \sqrt{\frac{\sigma_{0,2} + (X \cdot P_n)}{\sigma_{0,2} - (X \cdot P_n)}}$$

$\sigma_{0,2}$: elastic load of hub material	X: varies depending on hub shape (A, B, C)	P_n : pressure generated on the outer SIT-LOCK® diameter (see table)
---	--	--

Table of maximum limits with high bending moments

SIT-LOCK® 1

no axial displacement	not self-centering
-----------------------	--------------------

M_s = screw tightening torque	$P_w \text{ max con } M_b \text{ max}$ = max shaft pressure with BM max
M_t = transmissible torque without BM	$P_n \text{ max con } M_b \text{ max}$ = max hub pressure with BM max
F_{ax} = permissible axial force without BM	$P_w \text{ min con } M_b \text{ max}$ = min shaft pressure with BM max
P_w = pressure generated at the shaft without BM	$P_n \text{ min con } M_b \text{ max}$ = minimum hub pressure with BM max
P_n = pressure generated at the hub without BM	$M_{tBM} \text{ con } M_b \text{ max}$ = max transmissible torque with con BM
$M_b \text{ max}$ = maximum BM (BM = bending moment)	$F_{ax} \text{ con } M_b \text{ max}$ = max permissible axial force with BM

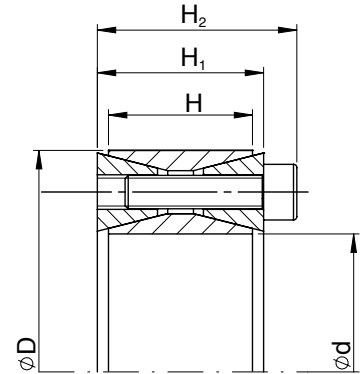

Dimensions [mm]				Clamping screws DIN 912 12.9			Values without bending moment					Values with maximum bending moment ($M_b \text{ max}$)						Weight [kg]
d x D	H	H ₁	H ₂	No.	Type	M_s [Nm]	M_t [Nm]	F_{ax} [kN]	P_w [N/mm ²]	P_n [N/mm ²]	$M_b \text{ max}$ [Nm]	$P_w \text{ max with } M_b \text{ max}$ [N/mm ²]	$P_n \text{ max with } M_b \text{ max}$ [N/mm ²]	$P_w \text{ min with } M_b \text{ max}$ [N/mm ²]	$P_n \text{ min con } M_b \text{ max}$ [N/mm ²]	$M_{tBM} \text{ with } M_b \text{ max}$ [Nm]	$F_{ax} \text{ with } M_b \text{ max}$ [kN]	
100 x 145	26	33	45	14	M12	127	9.703	194	198	137	7.220	335	231	61	42	6.480	129	2,00
110 x 155	26	33	45	14	M12	127	10.673	194	180	128	7.850	292	207	68	48	7.230	131	2,20
120 x 165	26	33	45	16	M12	127	13.262	221	188	137	8.970	320	232	89	64	9.770	163	2,40
130 x 180	34	38	50	20	M12	127	17.850	275	165	119	11.350	263	190	67	48	13.776	212	3,50
140 x 190	34	38	50	22	M12	127	21.089	301	168	124	10.180	239	176	97	71	18.469	263	3,90
150 x 200	34	38	50	24	M12	127	24.586	328	171	128	9.050	222	167	120	90	22.859	305	4,10
160 x 210	34	38	50	26	M12	127	28.343	354	173	132	7.900	210	160	136	103	27.219	340	4,30
170 x 225	38	44	58	22	M14	195	33.541	395	162	122	21.600	246	184	78	59	25.660	301	5,80
180 x 235	38	44	58	24	M14	195	38.636	429	166	128	18.980	228	175	104	80	33.652	374	6,10
190 x 250	46	52	66	29	M14	195	47.337	498	151	115	24.100	218	166	84	64	40.742	428	8,30
200 x 260	46	52	66	30	M14	195	53.261	533	154	118	21.200	205	158	103	79	48.860	488	8,70
220 x 285	50	56	72	26	M16	300	68.790	625	151	116	32.700	209	161	93	72	60.520	550	11,30
240 x 305	50	56	72	30	M16	300	86.127	718	159	125	20.350	187	147	131	103	83.688	697	12,20
260 x 325	50	56	72	34	M16	300	105.229	809	165	132	16.850	184	147	146	116	103.871	799	13,20
280 x 355	60	66	84	32	M18	410	128.456	918	145	114	38.450	178	140	112	88	122.566	875	19,30
300 x 375	60	66	84	36	M18	410	154.066	1.027	151	121	24.850	169	135	133	106	152.048	1.013	20,60
320 x 405	72	78	98	36	M20	590	211.342	1.321	152	120	37.300	174	137	130	102	208.024	1.300	29,70
340 x 425	72	78	98	36	M20	590	224.551	1.321	143	115	57.950	171	136	115	92	216.940	1.276	31,20
360 x 455	84	90	112	36	M22	790	289.095	1.606	141	111	74.650	172	136	110	87	279.290	1.551	42,30
380 x 475	84	90	112	36	M22	790	305.156	1.606	133	107	87.000	163	130	103	82	292.397	1.538	44,10
400 x 495	84	90	112	36	M22	790	321.217	1.606	127	102	150.500	172	139	82	66	283.778	1.418	46,20
420 x 515	84	90	112	40	M22	790	372.740	1.775	133	109	93.600	157	128	109	89	360.796	1.718	50,10
440 x 545	96	102	126	40	M24	1.000	447.549	2.034	128	103	113.200	154	124	102	82	432.996	1.968	64,50
460 x 565	96	102	126	40	M24	1.000	467.892	2.034	122	99	177.400	157	128	87	71	432.957	1.882	67,50
480 x 585	96	102	126	42	M24	1.000	511.273	2.130	123	101	168.200	152	125	94	77	482.813	2.011	71,20
500 x 605	96	102	126	44	M24	1.000	556.488	2.226	123	102	159.000	148	122	98	81	533.289	2.133	72,50
520 x 630	96	102	126	45	M24	1.000	591.149	2.274	121	100	194.500	148	122	94	78	558.235	2.147	80,20
540 x 650	96	102	126	45	M24	1.000	613.885	2.274	116	97	258.700	148	123	84	70	556.712	2.062	82,30
560 x 670	96	102	126	48	M24	1.000	676.552	2.416	119	100	212.900	142	119	96	80	642.180	2.293	85,10
580 x 690	96	102	126	50	M24	1.000	728.173	2.511	120	101	203.650	140	118	100	84	699.115	2.410	88,20
600 x 710	96	102	126	50	M24	1.000	753.282	2.511	116	98	267.900	140	118	92	78	704.033	2.346	91,30

Table of maximum limits with high bending moments

SIT-LOCK® 7

no axial displacement	self-centering
-----------------------	----------------

M_s = screw tightening torque	$P_w \text{ max con } M_b \text{ max}$ = max shaft pressure with BM max
M_t = transmissible torque without BM	$P_n \text{ max con } M_b \text{ max}$ = max hub pressure with BM max
F_{ax} = permissible axial force without BM	$P_w \text{ min con } M_b \text{ max}$ = min shaft pressure with BM max
P_w = pressure generated at the shaft without BM	$P_n \text{ min con } M_b \text{ max}$ = minimum hub pressure with BM max
P_n = pressure generated at the hub without BM	$M_{tBM} \text{ con } M_b \text{ max}$ = max transmissible torque with con BM
$M_b \text{ max}$ = maximum BM (BM = bending moment)	$F_{ax} \text{ con } M_b \text{ max}$ = max permissible axial force with BM

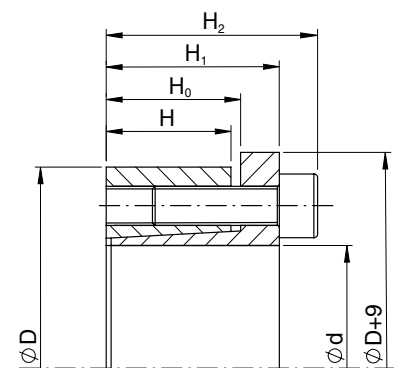

Dimensions [mm]					Clamping screws DIN 912 12.9			Values without bending moment					Values with maximum bending moment ($M_b \text{ max}$)						Weight [kg]
d x D	H	H ₀	H ₁	H ₂	No.	Type	M_s [Nm]	M_t [Nm]	F_{ax} [kN]	P_w [N/mm ²]	P_n [N/mm ²]	$M_b \text{ max}$ [Nm]	$P_w \text{ max with } M_b \text{ max}$ [N/mm ²]	$P_n \text{ max with } M_b \text{ max}$ [N/mm ²]	$P_w \text{ min with } M_b \text{ max}$ [N/mm ²]	$P_n \text{ min with } M_b \text{ max}$ [N/mm ²]	$M_{tBM} \text{ with } M_b \text{ max}$ [Nm]	$F_{ax} \text{ with } M_b \text{ max}$ [kN]	
70 x 110	24	30	40	50	8	M10	83	4.670	133	211	134	2.335	340	216	82	52	4.044	115	1,68
75 x 115	24	30	40	50	8	M10	83	5.004	133	197	128	2.510	310	202	84	55	4.328	115	1,77
80 x 120	24	30	40	50	8	M10	83	5.338	133	184	123	2.720	285	190	83	55	4.824	121	1,85
85 x 125	24	30	40	50	9	M10	83	6.380	150	195	133	3.210	294	200	96	65	5.513	130	1,95
90 x 130	24	30	40	50	9	M10	83	6.755	150	184	128	3.380	272	188	96	66	5.848	130	2,05
95 x 135	24	30	40	50	10	M10	83	7.923	167	194	137	3.980	282	198	106	75	6.850	144	2,15
100 x 145	26	32	44	56	8	M12	145	9.714	194	198	137	7.220	335	231	61	42	6.498	130	2,80
110 x 155	26	32	44	56	8	M12	145	10.686	194	180	128	7.850	292	207	68	48	7.250	132	3,10
120 x 165	26	32	44	56	9	M12	145	13.114	219	186	135	8.970	284	207	88	64	9.566	159	3,25
130 x 180	34	40	54	68	12	M12	145	18.943	291	175	126	11.350	273	197	77	56	15.166	233	4,65
140 x 190	34	40	54	68	9	M14	230	20.993	300	167	123	10.180	237	175	97	71	18.359	262	5,25
150 x 200	34	40	54	68	10	M14	230	24.992	333	173	130	10.200	230	173	116	87	22.815	304	5,80
160 x 210	34	40	54	68	11	M14	230	29.324	367	179	136	10.300	227	173	131	100	26.800	335	5,90
170 x 225	44	50	64	78	12	M14	230	33.989	400	142	107	21.600	226	171	58	44	26.242	309	8,20
180 x 235	44	50	64	78	12	M14	230	35.989	400	134	103	18.980	196	150	72	55	30.577	340	8,60
190 x 250	44	50	64	78	15	M14	230	47.485	500	159	121	24.100	226	172	92	70	40.914	431	9,90
200 x 260	44	50	64	78	15	M14	230	49.984	500	151	116	21.200	201	155	101	78	45.265	453	10,40
220 x 285	50	56	75	91	12	M16	355	61.133	556	134	104	32.700	192	148	76	59	51.652	470	14,10
240 x 305	50	56	75	91	15	M16	355	83.363	695	154	121	28.500	193	152	115	91	78.339	653	15,20
260 x 325	50	56	75	91	16	M16	355	96.330	741	151	121	36.950	191	153	111	89	88.961	684	16,20
280 x 355	60	66	87	105	16	M18	485	124.820	892	141	111	42.500	178	140	104	82	117.361	838	24,60
300 x 375	60	66	87	105	18	M18	485	150.460	1.003	148	118	51.150	184	147	112	90	141.498	943	25,60
320 x 405	74	81	101	121	18	M20	690	208.205	1.301	146	115	70.900	187	148	105	83	195.761	1.224	38,00
340 x 425	74	81	101	121	21	M20	690	258.080	1.518	160	128	87.800	203	162	117	94	242.685	1.428	38,40
360 x 455	86	94	116	138	18	M22	930	291.570	1.620	139	110	97.750	179	142	99	78	274.696	1.526	53,50
380 x 485	86	94	116	138	21	M22	930	359.060	1.889	154	121	120.450	196	154	112	88	338.254	1.780	57,80
400 x 495	86	94	116	138	21	M22	930	377.960	1.889	146	118	150.500	191	154	101	82	353.748	1.768	60,40
420 x 515	86	94	116	138	21	M22	930	396.690	1.889	139	113	133.100	173	141	105	86	373.694	1.779	63,00
440 x 535	86	94	116	138	21	M22	930	415.580	1.889	133	109	139.450	164	135	102	84	391.484	1.779	65,80
460 x 555	86	94	116	138	22	M22	930	455.352	1.980	133	110	177.400	168	139	98	81	419.374	1.823	68,50
480 x 575	86	94	116	138	24	M22	930	518.345	2.160	139	116	174.000	169	141	109	91	488.267	2.034	71,30
500 x 595	86	94	116	138	24	M22	930	540.000	2.160	133	112	182.000	161	135	105	88	508.405	2.034	74,00

High bending moment

Table of maximum limits with high bending moments

SIT-LOCK® 4 COMPACT

no axial displacement	self-centering
-----------------------	----------------

M_s = screw tightening torque	P_w max con M_b max = max shaft pressure with BM max
M_t = transmissible torque without BM	P_n max con M_b max = max hub pressure with BM max
F_{ax} = permissible axial force without BM	P_w min con M_b max = min shaft pressure with BM max
P_w = pressure generated at the shaft without BM	P_n min con M_b max = minimum hub pressure with BM max
P_n = pressure generated at the hub without BM	M_{tBM} con M_b max = max transmissible torque with con BM
M_b max = maximum BM (BM = bending moment)	F_{ax} con M_b max = max permissible axial force with BM

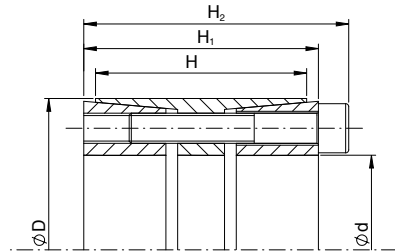

Dimensions [mm]				Clamping screws DIN 912 12.9			Values without bending moment					Values with maximum bending moment (M_b max)						Weight [kg]
d x D	H	H ₁	H ₂	No.	Type	M_s [Nm]	M_t [Nm]	F_{ax} [kN]	P_w [N/mm ²]	P_n [N/mm ²]	M_b max [Nm]	P_w max with M_b max [N/mm ²]	P_n max with M_b max [N/mm ²]	P_w min with M_b max [N/mm ²]	P_n min with M_b max [N/mm ²]	M_{tBM} with M_b max [Nm]	F_{ax} with M_b max [kN]	
70 x 110	50	60	70	8	M10	83	7.300	208	197	125	5.050	241	153	153	97	5.271	151	2,30
75 x 115	50	60	70	8	M10	83	7.800	208	184	120	5.400	222	145	146	95	5.628	150	2,40
80 x 120	50	60	70	10	M10	83	10.400	260	216	144	7.250	258	172	174	116	7.456	186	2,50
85 x 125	50	60	70	10	M10	83	11.100	260	203	138	7.700	240	163	166	113	7.994	188	2,60
90 x 130	50	60	70	11	M10	83	12.900	286	211	146	8.900	248	172	174	120	9.338	207	2,70
95 x 135	50	60	70	11	M10	83	13.600	286	200	141	9.400	233	164	167	118	9.828	207	2,90
100 x 145	60	70	82	10	M12	145	19.400	388	215	148	10.100	260	179	169	117	16.563	331	4,10
110 x 155	60	70	82	10	M12	145	21.400	388	195	138	11.100	233	165	157	111	18.296	333	4,30
120 x 165	60	70	82	11	M12	145	25.600	427	197	143	14.500	235	171	159	116	21.097	352	4,60
130 x 180	65	79	91	14	M12	145	35.300	544	205	148	19.750	261	188	149	108	29.425	453	6,70
140 x 190	65	79	91	15	M12	145	40.800	583	204	151	19.500	248	183	160	118	35.838	512	7,10
150 x 200	65	79	91	15	M12	145	43.700	583	191	143	27.300	242	182	140	105	34.123	455	7,60
160 x 210	65	79	91	16	M12	145	49.700	621	191	145	22.100	225	171	157	120	44.516	556	8,00
170 x 225	78	92	106	15	M14	230	67.500	795	194	146	30.950	246	186	142	107	59.986	706	10,80
180 x 235	78	92	106	15	M14	230	71.500	795	183	140	44.850	247	189	119	91	55.684	618	11,50
190 x 250	88	102	116	16	M14	230	80.500	848	156	118	54.500	222	169	90	68	59.245	624	14,80
200 x 260	88	102	116	18	M14	230	105.000	1.047	183	141	40.500	225	173	141	108	96.874	969	15,00
220 x 285	96	111	127	15	M16	355	119.000	1.082	159	123	75.900	222	172	96	75	110.764	1.006	20,00
240 x 305	96	111	127	20	M16	355	173.000	1.443	194	153	43.500	222	175	166	131	167.441	1.395	21,80
260 x 325	96	111	127	20	M16	355	187.600	1.443	179	143	67.500	214	171	144	105	175.035	1.346	23,00
280 x 355	96	111	131	15	M20	690	237.000	1.695	217	171	112.200	263	207	171	135	208.758	1.491	33,30
300 x 375	96	111	131	16	M20	690	270.900	1.806	215	172	125.300	257	205	173	138	240.180	1.601	30,80
320 x 405	124	136	156	20	M20	690	362.000	2.260	195	154	170.100	257	203	133	105	319.546	1.997	46,50
340 x 425	124	136	156	20	M20	690	384.000	2.260	184	147	207.000	247	198	121	97	323.430	1.902	49,00
360 x 455	140	155	177	20	M22	930	499.000	2.771	170	135	286.000	243	192	97	77	408.907	2.272	67,00
380 x 475	140	155	177	20	M22	930	526.000	2.771	161	129	351.000	237	186	85	67	391.758	2.062	70,00
400 x 495	140	155	177	22	M22	930	610.000	3.048	168	136	369.500	237	192	99	80	485.355	2.427	74,00
420 x 515	140	155	177	24	M22	930	698.000	3.325	175	143	287.000	233	190	117	95	636.266	3.030	77,00
440 x 535	140	155	177	24	M22	930	731.000	3.325	167	137	388.000	235	193	99	81	619.530	2.816	81,00
460 x 555	140	155	177	24	M22	930	765.000	3.325	160	132	464.000	232	192	88	73	608.218	2.644	84,00
480 x 575	140	155	177	25	M22	930	831.000	3.463	159	133	437.500	218	182	100	84	706.509	2.944	87,00
500 x 595	140	155	177	25	M22	930	866.000	3.463	153	129	437.000	206	173	100	84	747.654	2.991	92,00



Quarry excavator application: SIT-LOCK® 4 COMPACT for drums and SIT-LOCK® 14 for bucket wheel locking.



Locking conveyor chain wheels using SIT-LOCK® 4 COMPACT.

High bending moment

NOTES:

A series of horizontal dotted lines for writing notes.

In accordance with the SIT S.p.A. policy, for a constant improvement of our products, technical data contained in this catalog may be changed without notice.

SIT pulleys and related products are designed in Italy and manufactured and / or controlled in the group's SIT in the world:
ITALY: Val Brembilla / GERMANY: Brakei / FRANCE: Argenteuil / SPAIN: Barcelona / CHINA: Shanghai / INDIA: Pune
All the pulleys and components manufactured by SIT are in compliance with the RoHS regulation (RoSH Directive 2011/65/UE) and the REACH Directive (1907/2006).

SIT S.p.A. DOES NOT supply products for applications within the following markets: Aeronautical sector, Nuclear sector, Aerospace sector and Off-shore sector. SIT products are specifically designed for the industrial sector; therefore SIT does not assume any responsibility for the use of its products in the above mentioned sectors, being applications that require different safety factors from those of the industrial use for which they have been designed.



SIT S.p.A.
Viale A. Volta, 2
20047 Cusago (MI) - Italy
Tel. +39 02 89144 1
Fax +39 02 89144 293
export@sitspa.it
www.sitspa.com

Factory
Via G. Carminati, 15
24012 Val Brembilla (BG) - Italy

AUTHORIZED DISTRIBUTOR

SIT GERMANY

SIT ANTRIEBSELEMENTE GmbH
Rieseler Feld 9 (Gewerbegebiet West)
D - 33034 Brakel
Tel. +49 52 72 39 28 0
Fax +49 52 72 39 28 90
E-mail: info@sit-antriebselemente.de
Web: www.sit-antriebselemente.de

SIT SWITZERLAND

SIT (Schweiz) AG
Lenzbüel 13
CH - 8370 Sirmach
Tel. +41 71 969 50 00
Fax +41 71 969 50 01
E-mail: info@sit-antriebstechnik.ch
Web: www.sit-antriebstechnik.ch

SIT SPAIN

DINAMICA DRIVE SOLUTIONS S.A.
Ctra. N-II, Km 592,6
E - 08740 S. Andreu De La Barca
(Barcelona)
Tel. +34 93 653 35 00
Fax +34 93 653 35 08
E-mail: dinamica@dinamica.net
Web: www.dinamica.net

SIT FRANCE

FOGEX SAS
215, Rue Henri Barbusse
F - 95100 Argenteuil
Tel. +33 1 34 34 46 00
Fax +33 1 34 34 46 01
E-mail: info@fogex.com
Web: www.fogex.com

SIT USA

S.I.T. INDEVA, Inc.
11540-A Cordage Street
Charlotte, NC 28273
Tel. +1 704 357 8811
Fax +1 704 357 8866
E-mail: info@sit-indeva.com
Web: www.sit-elatech-usa.com

SIT CHINA

SIT INDEVA (SHANGHAI) LTD.
Building 2, 269 YuanZhong Road
Nanhui Industrial park
Pudong new area
PRC - 201300 Shanghai
Tel. +86 021 5108 2206
Fax +86 021 6486 3511
E-mail: info@sit-shanghai.com
Web: www.sit-shanghai.com

SIT INDIA

SIT PTC INDIA PVT. LTD.
Plot no. 677, s.no. 269/3
Paud Road, Bhugao
Taluka - Mulshi - Pune - 412 115
Maharashtra - India
Tel. +91 9158 5921 11
E-mail: a.nangre@sitspa.com
Web: www.sitspa.com