

Codex Bearing Units



An insert bearing is a deep groove ball bearing with a convex outside surface on outer ring and an extended inner ring with two bolts for mounting it on a shaft

Housings designs are available as flanged and take-up units and are made from durable HT200 cast iron material.

Housings are equipped with a grease nipple for external lubrication. Since the insert bearings itself requires high precision, the used grease should be of a particularly fine quality.

UC	205
Insert bearing	basic bearing series

NOMENCLATURE:

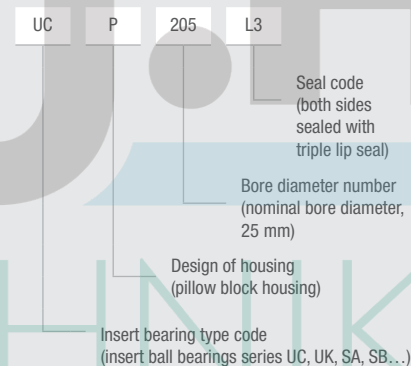

DESIGN OF HOUSING:

- P (pillow block)
- F (4-bolt flange unit)
- FL (2-bolt flange unit)

SEALING OF INSERT BEARINGS:

- DUAL SEAL**
 Nitrile rubber single lip seal with an additional shield
- TRIPLE LIP SEAL**
 Seal for contaminated environments
- FIVE LIP SEAL**
 Seal for very contaminated environments

Ball bearing units are used in many industrial applications due to their cost-efficiency. Ball bearing units are composed of an insert bearing mounted in a cast housing in various designs.

Housings and insert bearing combinations:

UCP Pillow Blocks

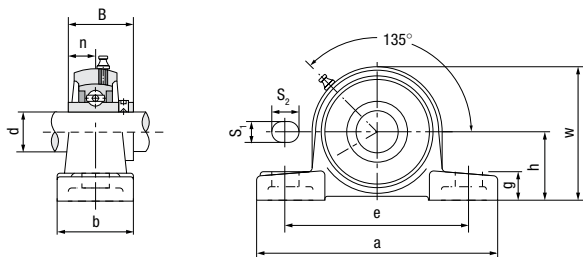

UCF 4-Bolt Flange Units

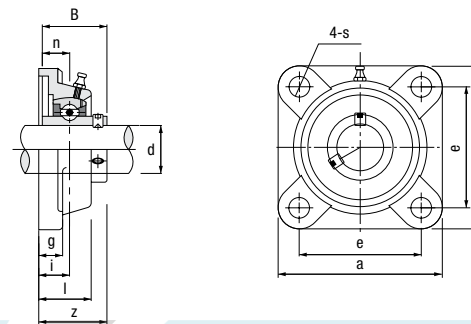

Bearing Unit	Bearing housing	Insert bearing	Main dimensions (mm)										Bolt	Weight (kg)	
			d	h	a	e	b	S1	S2	g	w	B			n
UCP201	P201	UC201	12	30,2	127	95	38	13	19	14	62	31	12,7	M10	0,65
UCP202	P202	UC202	15	30,2	127	95	38	13	19	14	62	31	12,7	M10	0,64
UCP203	P203	UC203	17	30,2	127	95	38	13	19	14	62	31	12,7	M10	0,63
UCP204	P204	UC204	20	33,3	127	95	38	13	19	14	65	31	12,7	M10	0,64
UCP205	P205	UC205	25	36,5	140	105	38	13	19	15	71	34,1	14,3	M10	0,76
UCP206	P206	UC206	30	42,9	160	121	44	17	20	17	84	38,1	15,9	M14	1,2
UCP207	P207	UC207	35	47,6	167	127	48	17	20	18	93	42,9	17,5	M14	1,46
UCP208	P208	UC208	40	49,2	184	137	54	17	20	18	100	49,2	19	M14	1,86
UCP209	P209	UC209	45	54,0	190	146	54	17	20	20	106	49,2	19	M14	2,06
UCP210	P210	UC210	50	57,2	206	159	60	20	23	21	113	51,6	19	M16	2,61
UCP211	P211	UC211	55	63,5	219	171	60	20	23	23	125	55,6	22,2	M16	3,23
UCP212	P212	UC212	60	69,8	241	184	70	20	23	25	138	65,1	25,4	M16	4,40

Bearing Unit	Bearing housing	Insert bearing	Main dimensions (mm)										Bolt	Weight (kg)
			d	a	e	i	g	l	s	z	B	n		
UCF201	F201	UC201	12	86	64	15	12	25,5	12	33,3	31	12,7	M10	0,59
UCF202	F202	UC202	15	86	64	15	12	25,5	12	33,3	31	12,7	M10	0,58
UCF203	F203	UC203	17	86	64	15	12	25,5	12	33,3	31	12,7	M10	0,57
UCF204	F204	UC204	20	86	64	15	12	25,5	12	33,3	31	12,7	M10	0,55
UCF205	F205	UC205	25	95	70	16	14	27	12	35,8	34,1	14,3	M10	0,73
UCF206	F206	UC206	30	108	83	18	14	31	12	40,2	38,1	15,9	M10	1,02
UCF207	F207	UC207	35	117	92	19	16	34	14	44,4	42,9	17,5	M12	1,33
UCF208	F208	UC208	40	130	102	21	16	36	16	51,2	49,2	19	M14	1,67
UCF209	F209	UC209	45	137	105	22	18	38	16	52,2	49,2	19	M14	2,0
UCF210	F210	UC210	50	143	111	22	18	40	16	54,6	51,6	19	M14	2,32
UCF211	F211	UC211	55	162	130	25	20	43	19	58,4	55,6	22,2	M16	3,12
UCF212	F212	UC212	60	175	143	29	20	48	19	68,7	65,1	25,4	M16	3,95

UCFL 2-Bolt Flange Units

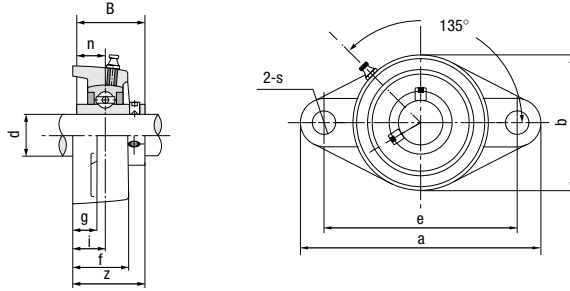

UC Insert bearings

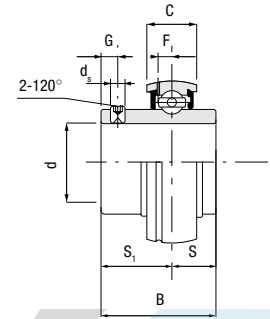

Bearing Unit	Bearing housing	Insert bearing	Main dimensions (mm)										Bolt	Weight (kg)	
			d	a	e	i	g	f	s	b	z	B			n
UCFL201	FL201	UC201	12	113	90	15	11	25,5	12	60	33,3	31	12,7	M10	0,45
UCFL202	FL202	UC202	15	113	90	15	11	25,5	12	60	33,3	31	12,7	M10	0,45
UCFL203	FL203	UC203	17	113	90	15	11	25,5	12	60	33,3	31	12,7	M10	0,45
UCFL204	FL204	UC204	20	113	90	15	11	25,5	12	60	33,3	31	12,7	M10	0,45
UCFL205	FL205	UC205	25	130	99	16	13	27	16	68	35,8	34,1	14,3	M14	0,58
UCFL206	FL206	UC206	30	148	117	18	13	31	16	80	40,2	38,1	15,9	M14	0,83
UCFL207	FL207	UC207	35	161	130	19	14	34	16	90	44,4	42,9	17,5	M14	1,1
UCFL208	FL208	UC208	40	175	144	21	14	36	16	100	51,2	49,2	19,0	M14	1,42
UCFL209	FL209	UC209	45	188	148	22	15	38	19	108	52,2	49,2	19,0	M16	1,75
UCFL210	FL210	UC210	50	197	157	22	15	40	19	115	54,6	51,6	19,0	M16	2,02
UCFL211	FL211	UC211	55	224	184	25	18	43	19	130	58,4	55,6	22,2	M16	2,8
UCFL212	FL212	UC212	60	250	202	29	18	48	23	140	68,7	65,1	25,4	M20	3,65

Insert bearing	Main dimensions (mm)									Dynamic load (kN)	Static load (kN)	Weight (kg)
	d	D	B	C	S	S1	G	ds	F			
UC201	12	47	31	17	12,7	18,3	4,8	M6x1	3,7	12,8	6,6	0,20
UC202	15	47	31	17	12,7	18,3	4,8	M6x1	3,7	12,8	6,6	0,19
UC203	17	47	31	17	12,7	18,3	4,8	M6x1	3,7	12,8	6,6	0,18
UC204	20	47	31	17	12,7	18,3	4,8	M6x1	3,7	12,8	6,6	0,16
UC205	25	52	34,1	17	14,3	19,8	5	M6x1	3,9	14,0	7,85	0,19
UC206	30	62	38,1	19	15,9	22,2	5	M8x1	5	19,45	11,25	0,30
UC207	35	72	42,9	20	17,5	25,4	7	M8x1	5,7	25,7	15,2	0,45
UC208	40	80	49,2	21	19	30,2	8	M8x1	6,2	29,5	18,1	0,60
UC209	45	85	49,2	22	19	30,2	8	M8x1	6,4	32,7	20,9	0,65
UC210	50	90	51,6	24	19	32,6	10	M10x1	6,5	35	23,2	0,75
UC211	55	100	55,6	25	22,2	33,4	10	M10x1	7	43,3	29,2	0,99
UC212	60	110	65,1	27	25,4	39,7	10	M10x1	7,6	47,7	32,8	1,32

SA Insert bearings

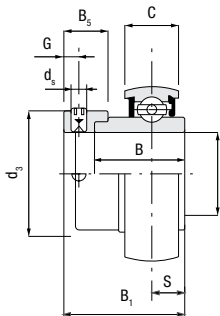

Insert bearing	Main dimensions (mm)											Dynamic load (kN)	Static load (kN)	Weight (kg)
	d	D	B	B1	C	S	ds	G	F	B5	D3			
SA201	12	40	28,6	19,1	12	6,5	M6x1	4,8	3,4	13,5	28,6	9,6	4,6	0,12
SA202	15	40	28,6	19,1	12	6,5	M6x1	4,8	3,4	13,5	28,6	9,6	4,6	0,1
SA203	17	40	28,6	19,1	12	6,5	M6x1	4,8	3,4	13,5	28,6	12,8	6,6	0,1
SA204	20	47	31	21,5	14	7,5	M6x1	4,8	4,2	13,5	33,3	12,8	6,6	0,16
SA205	25	52	31	21,5	15	7,5	M6x1	4,8	4,3	13,5	38,1	14,0	7,85	0,2
SA206	30	62	35,7	23,8	16	9,0	M8x1	6	5	15,9	44,5	19,45	11,25	0,3
SA207	35	72	38,9	25,4	17	9,5	M8x1	6,8	5,6	17,5	55,6	25,7	15,2	0,42
SA208	40	80	43,7	30,2	18	11	M8x1	6,8	5,9	18,3	60,3	29,5	18,1	0,6
SA209	45	85	43,7	30,2	19	11	M10x1	6,8	6,1	18,3	63,5	32,7	20,9	0,64
SA210	50	90	43,7	30,2	20	11	M10x1	6,8	6,5	18,3	69,9	35	23,2	0,72
SA211	55	100	48,3	32,5	21	12	M10x1	8	7	20,7	76,2	43,3	29,2	1
SA212	60	110	53,1	37,2	22	13,5	M10x1	8	7,4	22,3	84,2	47,7	32,8	1,34

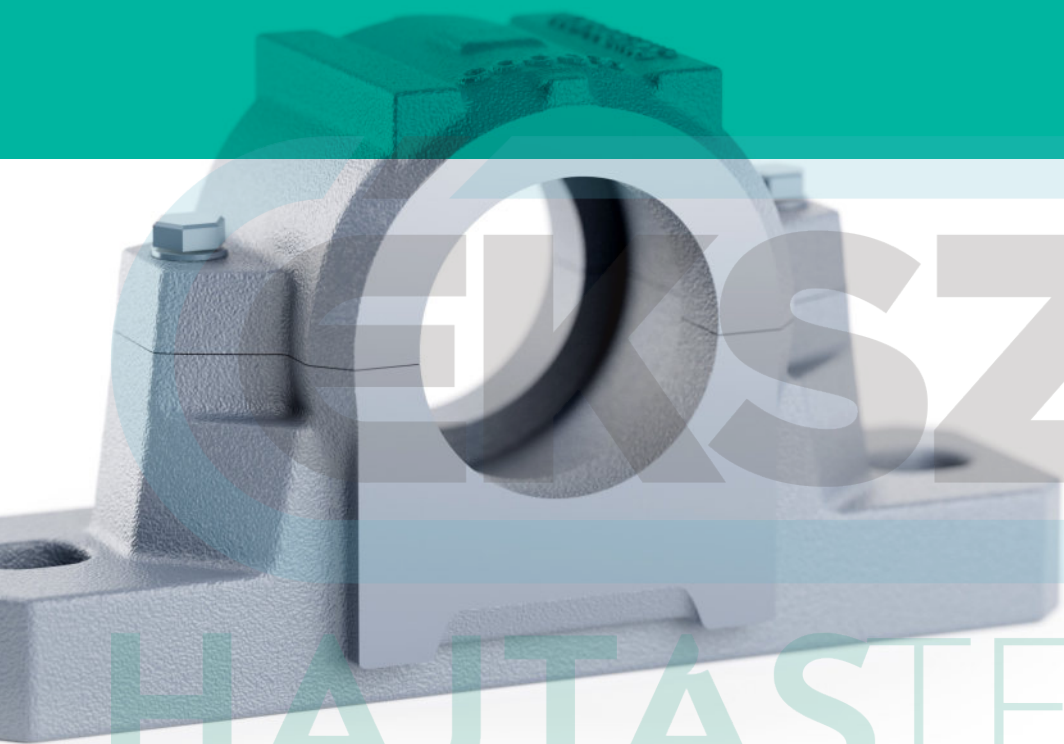

For installed bearings, they assure the best conditions to maximize their performance, their life time and to minimize maintenance. The split plummer block housings are typically used with self-aligning ball bearings or spherical roller bearings fitted on straight or stepped shafts. The bearings can be mounted on adapter or withdrawal sleeves or directly on to cylindrical shaft seats.

Plummer block housings are split units (cap and base) and assembly is carried out by attaching both parts together with bolts. Two fixing holes on the base are available for installation of the unit to a supporting structure.

The plummer block housings are made of high-quality grey cast iron to provide high tensile strength.

Sealing arrangement

Proper sealing keeps the interior contact surfaces debris-free and the interior properly lubricated. SNL plummer (pillow) block housings are available with different standard sealing solutions.

Codex SNL Plummer housings

Pillow (plummer) block housings SNL type are the most popular type on the market. They are well adapted to various applications and are designed for the best price/performance ratio.

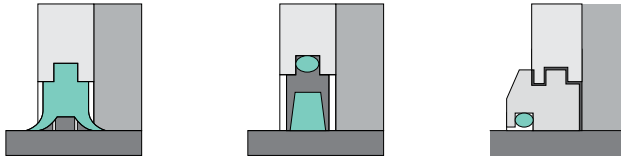

Structural properties	TSNG Double lip seal	TSN Felt strip seal	TSU Labyrinth seal
Operating temperature (°C)	-40...+100	-40...+100	-40...+200
Circumferential speed (m/s)	< 8	< 15	> 15
Possible misalignment (Degrees)	0,5...1	< 0,5	< 0,3
Relubrication			
Low friction			
Suitable for floating bearings			
Vertical installation			

FELT SEALS OR STRIPS (TSN)

Felt seals are compatible with rubber seals but must be used for grease lubrication only. Felt seals are not suitable for dusty or moist environments. Their allowable peripheral speed, as a guideline, is 4m/s. A felt seal can be cut into two pieces that are respectively fitted into the seal grooves on the upper and lower plummer block housings. This feature greatly simplifies the assembly procedure for plummer blocks.

END COVERS (ASNH)

In some applications, the shaft end is designed to terminate inside the pillow block. For this design, positive fitting end-cover inserts are available to help seal out contaminants and retain lubricants – providing additional protection to the bearing.

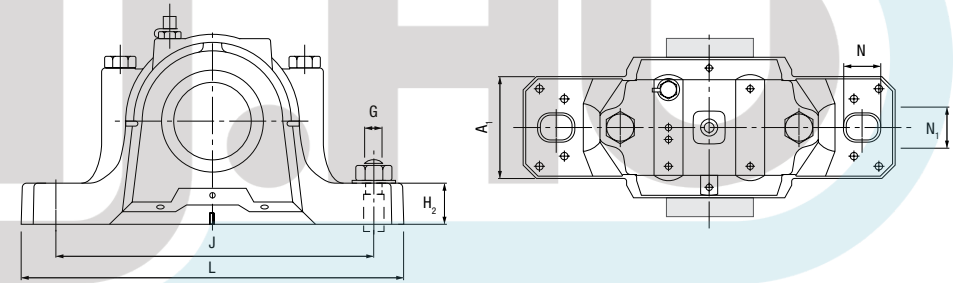

DOUBLE-LIP SEALS (TSNG)

Double-lip seals are the most common seal design used with SNL split plummer blocks. These are general all-purpose elastomer seals that can protect in moderately contaminated environments. The seal is split into two 180-degree halves for easy installation. The seal element runs against the shaft surface and should be used in grease lubricated blocks.

LABYRINTH SEALS (TSU)

Labyrinth seals are made up of a single metal ring component that interconnects with the grooves in the housing to form a labyrinth gap. The inside diameter of the metal ring contains an O-ring that creates an interference fit with the shaft so that the ring will rotate with the shaft. Labyrinth seals can be used on high-speed applications and in moderately contaminated environments.

Type	A (mm)	H (mm)	H1 (mm)	L (mm)	N (mm)	N1 (mm)	J (mm)	A1 (mm)
SNL 511	95	128	70	255	23	18	210	70
SNL 512	105	134	70	255	23	18	210	70
SNL 513	110	149	80	275	24	18	230	80
SNL 515	115	155	80	280	24	18	230	80
SNL 516	120	177	95	315	28	22	260	90
SNL 517	125	183	95	320	28	22	260	90
SNL 518	140	194	100	345	28	22	290	100
SNL 520	160	218	122	380	32	26	320	110
SNL 522	175	242	125	410	32	26	350	120
SNL 524	185	271	140	410	32	26	350	120
SNL 526	190	290	150	445	35	28	380	130
SNL 528	205	302	150	500	42	35	420	150

Table of typical usage of SNL plummer block with bearing, adapter sleeve, sealing arrangement, end cover and locating ring.

Shaft Dia, (mm)	Housing No,	Bearing No,		Adapter Sleeve	Sealing Arrangement		End Cover	Locating Ring	
		Self-Alig, Ball	Spherical Roller		TSU	TSNA-G		Number	Qty
40	SNL 511	1309K	21309K	H309	-	TSNG 609	ASNH 511	100 x 9,5	2
	SNL 511	2309K	22309K	H2309	-	TSNG 609	ASNH 511	100 x 8	1
45	SNL 512	1310K	21310K	H310	-	TSNG 610	ASNH 512	110 x 10,5	2
	SNL 512	2310K	22310K	H2310	-	TSNG 610	ASNH 512	110 x 8	1
50	SNL 511	1211K	-	H211	TSU 511	TSNG 511	ASNH 511	100 x 11,5	2
	SNL 511	2211K	22211K	H311	TSU 511	TSNG 511	ASNH 511	100 x 9,5	2
	SNL 513	1311K	21311K	H311	-	TSNG 611	ASNH 513	120 x 11	2
	SNL 513	2311K	22311K	H2311	-	TSNG 611	ASNH 513	120 x 8	1
55	SNL 512	1212K	-	H212	TSU 512	TSNG 512	ASNH 512	110 x 13	2
	SNL 512	2212K	22212K	H312	TSU 512	TSNG 512	ASNH 512	110 x 10	2
	SNL 515	1312K	21312K	H312	-	TSNG 612	ASNH 515	130 x 12,5	2
	SNL 515	2312K	22312K	H2312	-	TSNG 612	ASNH 515	130 x 10	1
60	SNL 513	1213K	-	H213	TSU 513	TSNG 513	ASNH 513	120 x 14	2
	SNL 513	2213K	22213K	H313	TSU 513	TSNG 513	ASNH 513	120 x 10	2
	SNL 516	1313K	21313K	H313	-	TSNG 613	ASNH 516	140 x 12,5	2
	SNL 516	2313K	22313K	H2313	-	TSNG 613	ASNH 516	140 x 10	1
65	SNL 515	1215K	-	H215	TSU 515	TSNG 515	ASNH 513	130 x 15,5	2
	SNL 515	2215K	22215K	H315	TSU 515	TSNG 515	ASNH 513	130 x 12,5	2
	SNL 518	1315K	21315K	H315	-	TSNG 615	ASNH 518	160 x 14	2
	SNL 518	2315K	22315K	H2315	-	TSNG 615	ASNH 518	160 x 10	1
70	SNK 516	1216K	-	H217	TSU 516	TSNG 516	ASNH 516	140 x 16	2
	SNK 516	2216K	22216K	H316	TSU 516	TSNG 516	ASNH 516	140 x 12,5	2
75	SNL 517	1217K	-	H217	TSU 517	TSNG 517	ASNH 517	150 x 16,5	2
	SNL 517	2217K	22217K	H317	TSU 517	TSNG 517	ASNH 517	150 x 12,5	2
	SNL 520	1317K	21317K	H317	-	TSNG 617	ASNH 520	180 x 14,5	2
	SNL 520	2317K	22317K	H2317	-	TSNG 617	ASNH 520	180 x 10	1
80	SNL 518	1218K	-	H218	TSU 518	TSNG 518	ASNH 518	160 x 17,5	2
	SNL 518	2218K	22218K	H318	TSU 518	TSNG 518	ASNH 518	160 x 12,5	2
	SNL 518	-	23218K	H2318	TSU 518	TSNG 518	ASNH 518	160 x 12,5	1
85	SNL 522	-	22319K	H2319	-	TSNG 619	ASNH 522	200 x 13	1
90	SNL 520	1220K	-	H220	TSU 520	TSNG 520	ASNH 520	180 x 18	2
	SNL 520	2220K	22220K	H320	TSU 520	TSNG 520	ASNH 520	180 x 12	2
	SNL 520	-	23220K	H2320	TSU 520	TSNG 520	ASNH 520	180 x 9,7	1
	SNL 524	-	22320K	H2320	-	TSNG 620	ASNH 524	215 x 13	1
100	SNL 522	1222K	-	H222	TSU 522	TSNG 522	ASNH 522	200 x 21	2
	SNL 522	2222K	22222K	H322	TSU 522	TSNG 522	ASNH 522	200 x 13,5	2
	SNL 522	-	23222K	H2322	TSU 522	TSNG 522	ASNH 522	200 x 10,2	1
110	SNL 524	-	22224K	H3124	TSU 524	TSNG 524	ASNH 524	215 x 14	2
	SNL 524	-	23224K	H2324	TSU 524	TSNG 524	ASNH 524	215 x 10	1

